

ELECTRICALLY OPERATED DOUBLE DIAPHRAGM PUMPS

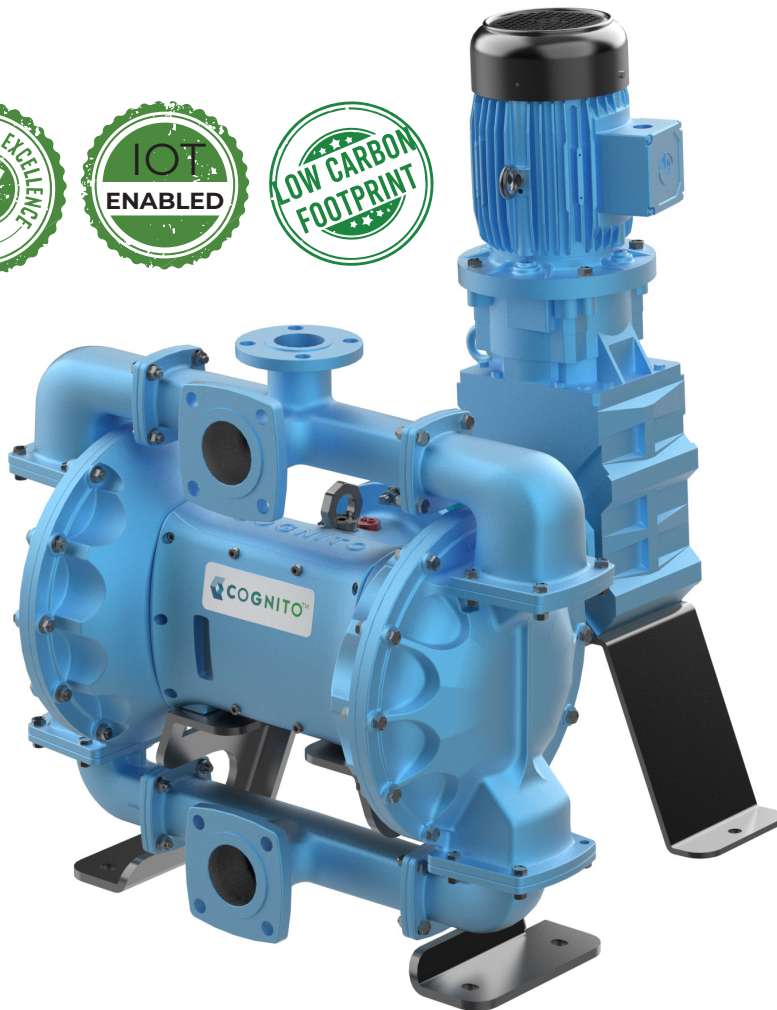

-  Higher Energy Efficiency
-  Run Dry Capable
-  Swift ROI/ Payback
-  Self-Priming
-  Seal-Less Pump
-  Handles Solids
-  Containment Chamber Equipped with Leak Detection
-  Predictive Maintenance & Remote Monitoring
-  Low Maintenance Cost







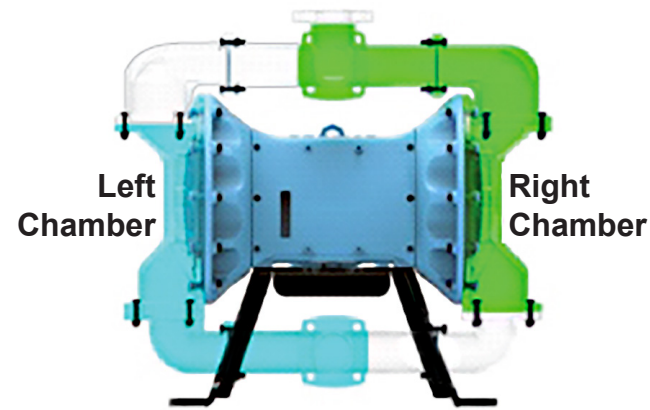

Cognito EODD is a Smart, IoT-enabled Electrically Operated Double Diaphragm pump. It is engineered and designed for various industrial application considering energy efficiency, safety, reliability, easy to use, maintenance friendly & long-lasting life.

Operating Principle

The pump is driven by an electric motor with a reduction gearbox. This in turn drives an eccentric shaft to operate the Diaphragms. When the eccentric shaft rotates and reaches peak on one side, example right side of the chamber, at the same time left side of the chamber reaches valley. This causes extrusion of right diaphragm and intrusion of left diaphragm. As a result positive pressure is built on right side (green) and vacuum on the left side (blue).



Key Benefits

-  Smoothly Handles Highly Abrasive, Corrosive, Shear Sensitive & Viscous Fluids
-  Highly Energy Efficient Pump with Significant Reduction in Energy Consumption
-  Robust Mechanism with Hassle-Free Maintenance
-  Low MTRR and High MTBF
-  Remote Performance Monitoring of Pump
-  Patented Diaphragm Designed for Better Performance and Longer Life
-  Reduced Operating Cost
-  Swift ROI/Payback

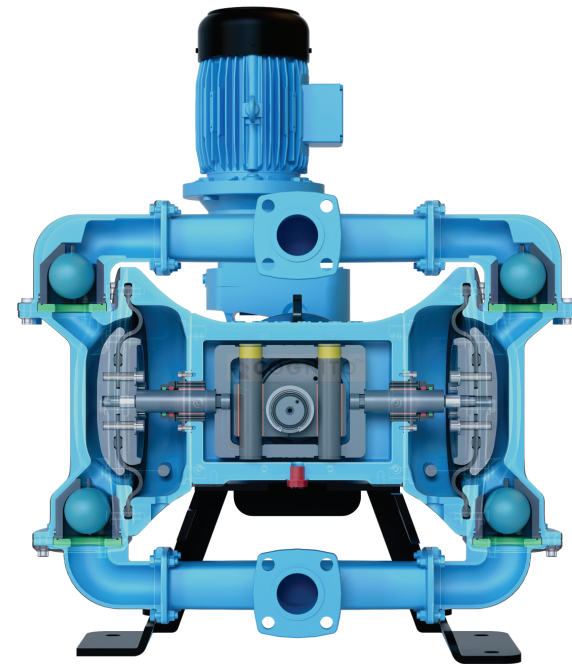

Applications

Slip Recirculation
Mixing Tank Transfer
Slip Casting House
Glazing

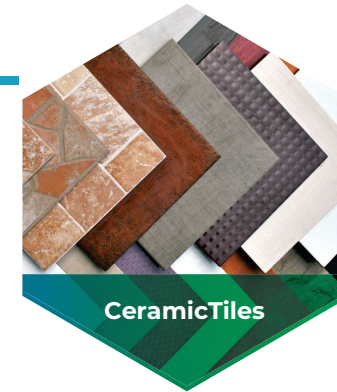

Ceramic Tiles



Sanitaryware



Tableware & Insulators



Filter Press



Water & Wastewater Treatment



Pulp & Paper

Applications

Slurry Transfer
Filter Press Feeding
Sludge Transfer
Effluent Transfer
Loading & Unloading of Equilization Tank

Applications

Raw Material Transfer
Emulsion Transfer
Solvent Transfer



Paint & Dye



Speciality Chemicals



Inks

KEY BENEFITS

- Robust Design
- Ultra-Efficient
- Handles Solids
- IoT Enable

Unique Design Feature

- Oversized diaphragms and reduced stroke length - Enhances diaphragm life
- Replaceable hardened stainless steel stopper cages / seats - Extends manifold life when pumping abrasive fluids
- Protects pumping mechanism from contact with process fluids
- Equipped with Leak Detection - Protects process

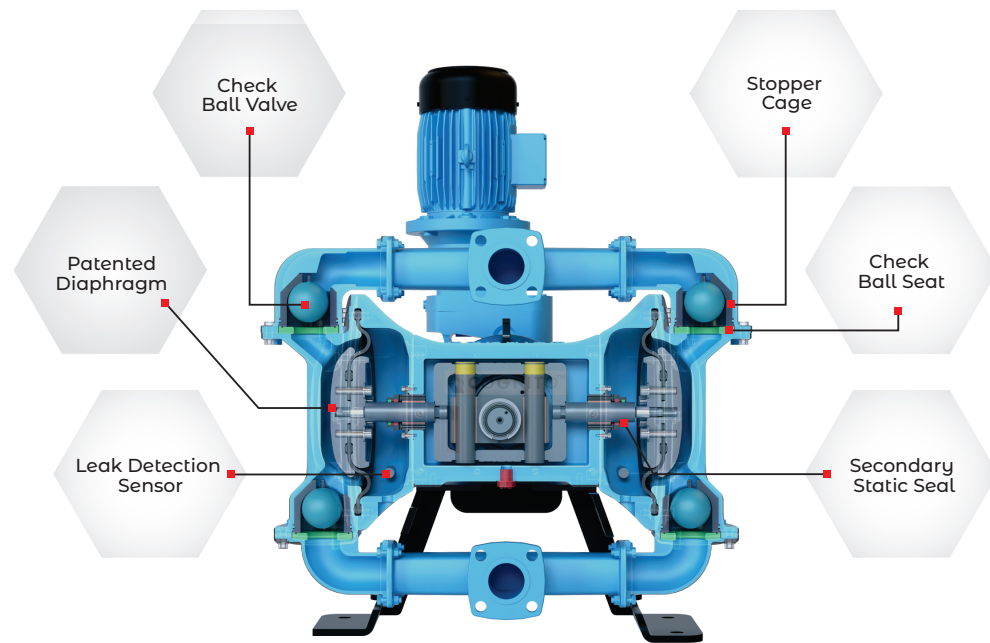

COGNITO EODD SPECIFICATIONS

Cognito EODD	4" (101 mm)	3" (76mm)	2" (50mm)
Operation	Electric		
Maximum Flow Rate GPM: (LPM)	211 (800)	135 (510)	79 (300)
Max Operating Pressure : PSI (BAR)	87 (6)	116 (8)	116 (8)
Materials of Construction			
Pump Body	Aluminum or Stainless Steel		
Diaphragm & Check Ball	Neoprene, Santoprene, or PTFE		
Maximum Suction Lift : FT (M)	26' (8) Wet 18' (5.5) Dry	26' (8) Wet 16' (5.1) Dry	26' (8) Wet 14' (4.2) Dry
Solids Handling : IN (MM)	.35" (9mm)	.27" (7mm)	.19" (5mm)
Motor & Gear Box : HP	7.5hp, 10hp	5hp, 7.5hp	3hp, 5hp
Sound Level	<80 db		
Displacement Per Stroke : GAL (L)	1.25 (4.75)	.76 (2.9)	.39 (1.48)

2" EODD PUMP PERFORMANCE

Specifications - 2" EODD

Suction / Discharge Port Size : IN (MM)	2" (50)
Fluid Port Connection Type : Alum (SS)	150# ANSI (FNPT)
Maximum Flow Rate GPM: (LPM)	79 (300)
Max Operating Pressure : PSI (BAR)	116 (8)
Ambient Temperature F (C)	-4°F to +131°F (-20°C to +55°C)
Operating Temperature	14°F to 230°F (-10°C to +110°C)
Solids Handling : IN (MM)	0.19" (5)
Heads Up To : FT (M)	262 (80)
Displacement Per Stroke : GAL (L)	.39 (1.48)
Maximum Suction Life : FT (M)	26+ Wet / 14 Dry (8+ Wet / 4.2 Dry)*
Motor & Gear Box : HP	3hp & 5hp
Sound Level	<80 db

*Applicable to Santoprene & PTFE Diaphragms only

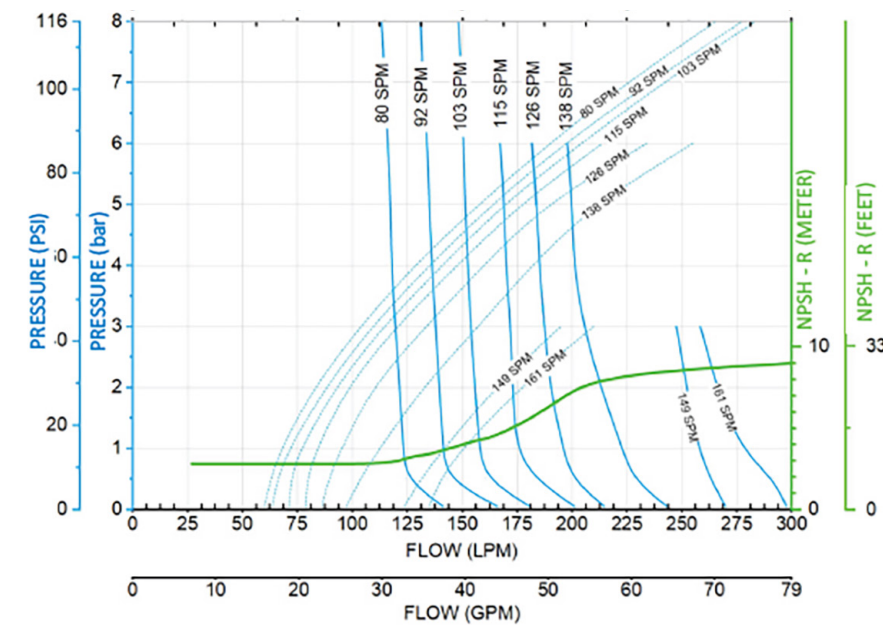

Notes :

1. Use 5 hp / 3.7 kW motor for above 4 AMPs
2. For SPM 161 & 149, contact Warren Rupp
3. The performance curve is based on following: SANTOPRENE elastomer fitted pump, flooded suction, water at ambient conditions 25°C, with COGNITO Dampener
4. The performance result may deviate in excess of 5% based on elastomer.
5. Performance vary based on Viscosity
6. NPSH-R curve @6bar Max. discharge condition

3" EODD PUMP PERFORMANCE

Specifications - 3" EODD

Suction / Discharge Port Size : IN (MM)	3" (76)
Fluid Port Connection Type : Alum (SS)	150# ANSI (FNPT)
Maximum Flow Rate GPM: (LPM)	135 (510)
Max Operating Pressure : PSI (BAR)	116 (8)
Ambient Temperature F (C)	-4°F to +131°F (-20°C to +55°C)
Operating Temperature	14°F to 230°F (-10°C to +110°C)
Solids Handling : IN (MM)	0.27" (7)
Heads Up To : FT (M)	262 (80)
Displacement Per Stroke : GAL (L)	.76 (2.9)
Maximum Suction Life : FT (M)	26+ Wet / 14 Dry (8+ Wet / 4.2 Dry)*
Motor & Gear Box : HP	5hp & 7.5hp
Sound Level	<80 db

*Applicable to Santoprene & PTFE Diaphragms only



4" EODD PUMP PERFORMANCE

Specifications - 4" EODD

Suction / Discharge Port Size : IN (MM)	4" (102)
Fluid Port Connection Type : Alum (SS)	150# ANSI (BSP)
Maximum Flow Rate GPM: (LPM)	211 (800)
Max Operating Pressure : PSI (BAR)	87 (6)
Ambient Temperature F (C)	-4°F to +131°F (-20°C to +55°C)
Operating Temperature	14°F to 230°F (-10°C to +110°C)
Solids Handling : IN (MM)	0.35" (9)
Heads Up To : FT (M)	197 (60)
Displacement Per Stroke : GAL (L)	1.25 (4.75)
Maximum Suction Life : FT (M)	26+ Wet / 18 Dry (8+ Wet / 5.5 Dry)*
Motor & Gear Box : HP	7.5hp & 10hp
Sound Level	<80 db

*Applicable to Santoprene & PTFE Diaphragms only

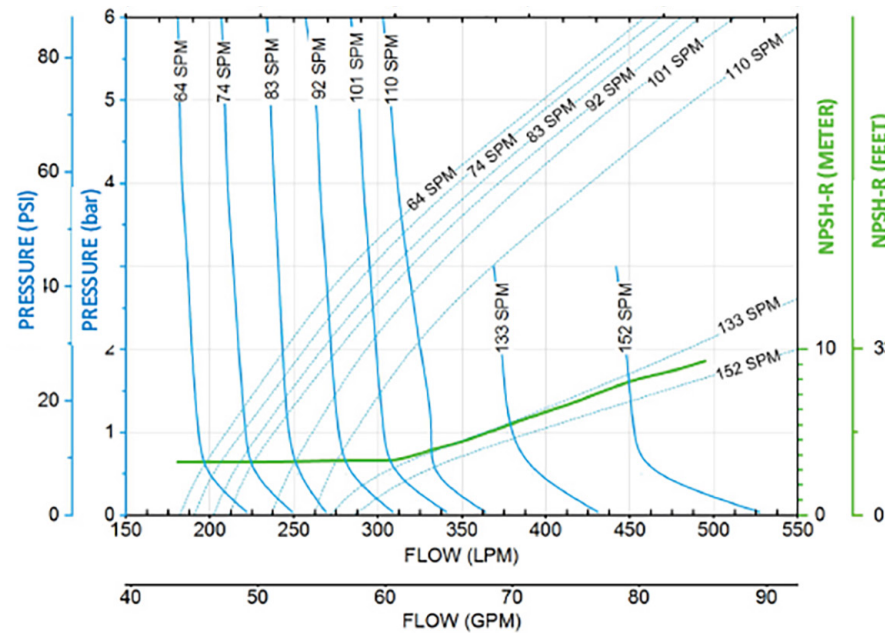

Notes :

1. Use 7.5 hp / 5.5 kW motor for above 7 AMPs
2. For SPM 152 & 133, contact Warren Rupp
3. The performance curve is based on following: SANTOPRENE elastomer fitted pump, flooded suction, water at ambient conditions 25°C, with COGNITO Dampener
4. The performance result may deviate in excess of 5% based on elastomer.
5. Performance vary based on Viscosity
6. NPSH-R curve @6bar Max. discharge condition

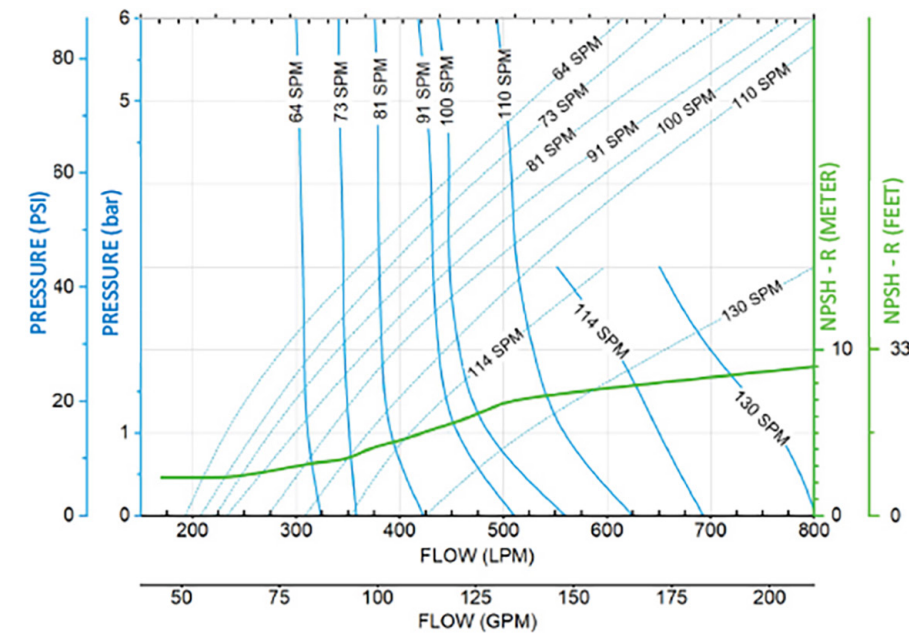

Notes :

1. Use 10 hp / 7.5 kW motor for above 10 AMPs
2. For SPM 130 & 114, contact Warren Rupp
3. The performance curve is based on following: SANTOPRENE elastomer fitted pump, flooded suction, water at ambient conditions 25°C, with COGNITO Dampener
4. The performance result may deviate in excess of 5% based on elastomer.
5. Performance vary based on Viscosity
6. NPSH-R curve @6bar Max. discharge condition

Inline Arrangement

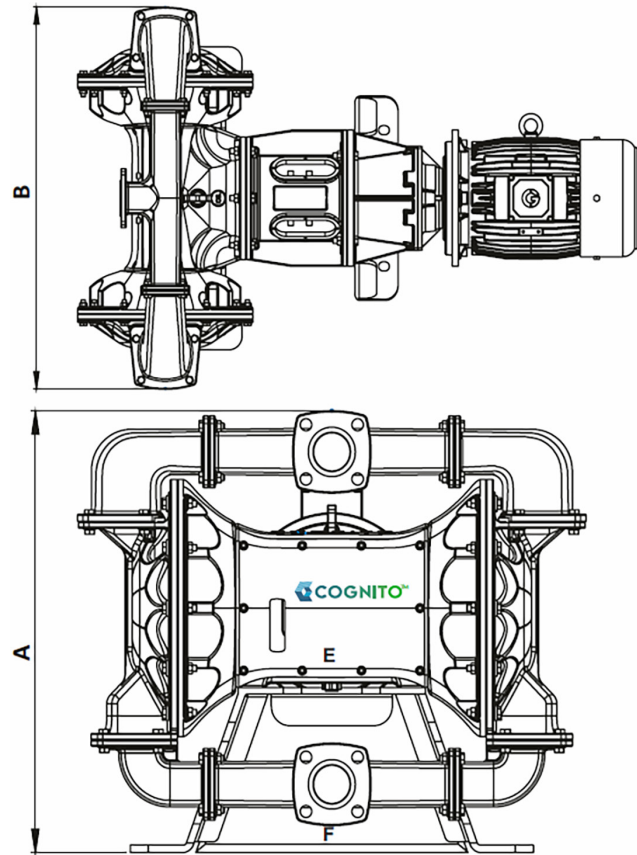

Dimensions & Weight - Inline



Dimension & Weight - Inline		4" (101 mm)	3" (76mm)	2" (50mm)
Aluminum				
Height w/o Dampener: IN (mm)	A	32.68" (830)	27.56" (700)	23.62" (600)
Width: IN (mm)	B	39.76" (1010)	33.07" (840)	28.93" (735)
Ref Length: IN (mm)	C	59.84" (1520)	50.98" (1295)	41.73 (1060)
Approx. Shipping Weight: LBS. (kg) Bare Pump	W	1,071 (486)	597 (271)	315 (143)
Approx. Shipping Weight: LBS. (kg) Pump + Motor + Gear Box	W	1437 (652)	875 (397)	526 (239)
Stainless Steel				
Height: IN (mm)	A	32.68" (830)	27.56" (700)	22.44" (570)
Width: IN (mm)	B	39.76" (1010)	33.07" (840)	28.93" (735)
Ref Length: IN (mm)	C	59.84" (1520)	50.98" (1295)	41.73 (1060)
Approx. Shipping Weight: LBS. (kg) Bare Pump	W	1203 (546)	685 (311)	372 (169)
Approx. Shipping Weight: LBS. (kg) Pump + Motor + Gear Box	W	1569 (712)	963 (437)	584 (265)



Vertical Arrangement

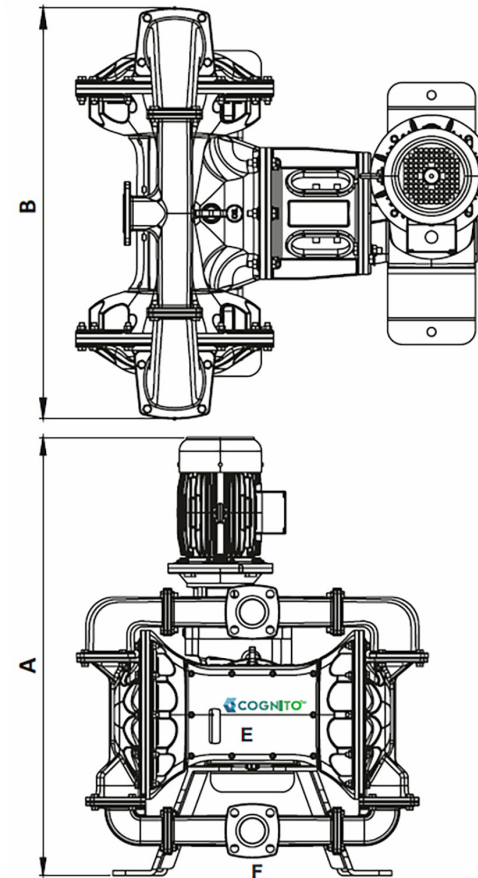

Dimensions & Weight - Vertical



Dimension & Weight - Vertical		4" (101 mm)	3" (76mm)	2" (50mm)
Aluminum				
Ref Height: IN (mm)	A	49.21" (1250)	41.33" (1050)	38.19" (970)
Width: IN (mm)	B	39.37" (1000)	33.7" (840)	28.93" (735)
Ref Length: IN (mm)	C	44.09" (1120)	32.48" (825)	30.51" (775)
Approx. Shipping Weight: LBS. (kg) Bare Pump	W	1027 (466)	553 (251)	271 (123)
Approx. Shipping Weight: LBS. (kg) Pump + Motor + Gear Box	W	1393 (632)	831 (377)	482 (219)
Stainless Steel				
Height: IN (mm)	A	47.24" (1200)	41.33" (1050)	38.19" (970)
Width: IN (mm)	B	39.76" (1010)	33.07" (840)	28.93" (735)
Ref Length: IN (mm)	C	39.96" (1015)	32.48" (825)	30.51" (775)
Approx. Shipping Weight: LBS. (kg) Bare Pump	W	1159 (526)	641 (291)	328 (149)
Approx. Shipping Weight: LBS. (kg) Pump + Motor + Gear Box	W	1525 (692)	919 (417)	540 (245)



Working Principle

A pulsation dampener uses a flexible diaphragm to separate a liquid chamber from a compressed air chamber. A rod connected to the centre of the diaphragm activates the air inlet and exhaust which automatically admits or exhausts air to the air chamber. This maintains the diaphragm in mid-range stroke to eliminate flow pulsation & pressure spikes.

Cognito Dampeners are suitable for EODD pump models and are available in Aluminum and Stainless-Steel wetted housings

Working Principle

Dampener Size	Compatible Pump Size	Air Inlet Size	Max Pressure	Fluid Port
2"	1"	1/8" NPT	116 PSI (8 bar)	2" 150# ANSI
	1.5"	1/8" NPT	116 PSI (8 bar)	2" 150# ANSI
	2"	1/8" NPT	116 PSI (8 bar)	2" 150# ANSI
3"	3"	1/8" NPT	116 PSI (8 bar)	3" 150# ANSI
	4"	1/8" NPT	116 PSI (8 bar)	3" 150# ANSI
Working Ambient Temperature			-20°C to +55°C	
Operating Temperature			-10°C to +90°C	

Note: Contact Warren Rupp for Polypropylene Dampener

Dimensional Drawing

2" Aluminum Dampener

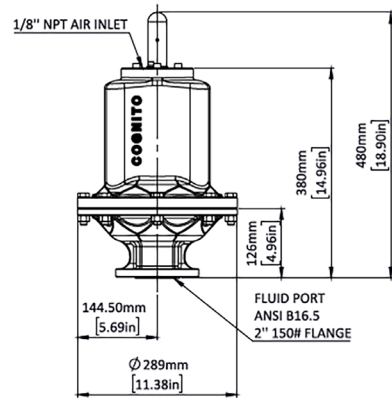

3" Aluminum Dampener

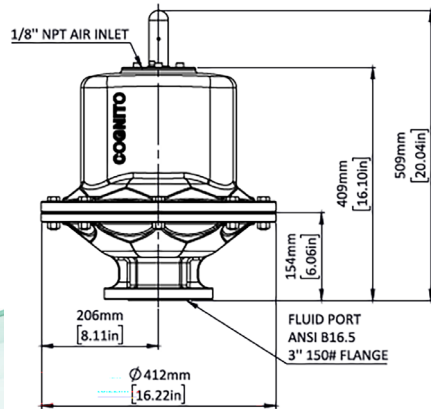

2" Stainless Steel Dampener

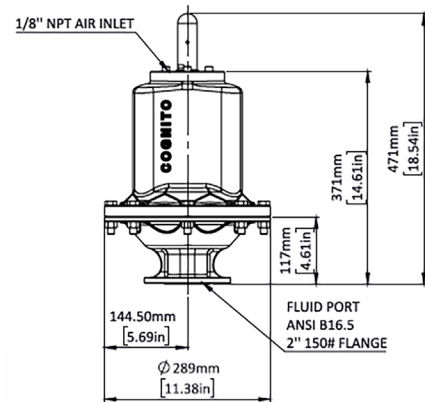

3" Stainless Steel Dampener

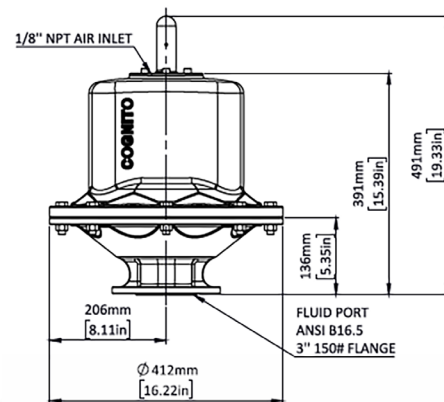

Material of Construction

Size	Model Number	Wetted Parts	
		Body	Diaphragm
2"	2AS	Aluminum	Santoprene
	2AP	Aluminum	Santoprene Backup / PTFE
	2SS	Stainless Steel	Santoprene
3"	2SP	Stainless Steel	Santoprene Backup / PTFE
	3AS	Aluminum	Santoprene
	3AP	Aluminum	Santoprene Backup / PTFE
	3SS	Stainless Steel	Santoprene
	3SP	Stainless Steel	Santoprene Backup / PTFE

- Do Not Run Dampener Without Air Supply
- Recommended Air Inlet Pressure : 14 PSI (1 bar) Higher from the Discharge Pressure
- This Dampener is Automatic Air Controlling Type

COGNITOsMartiNSIGHTS, a web-based portal, can be accessed from anywhere and provides real-time updates for all your installed COGNITO pumps helping you remotely monitor critical applications.

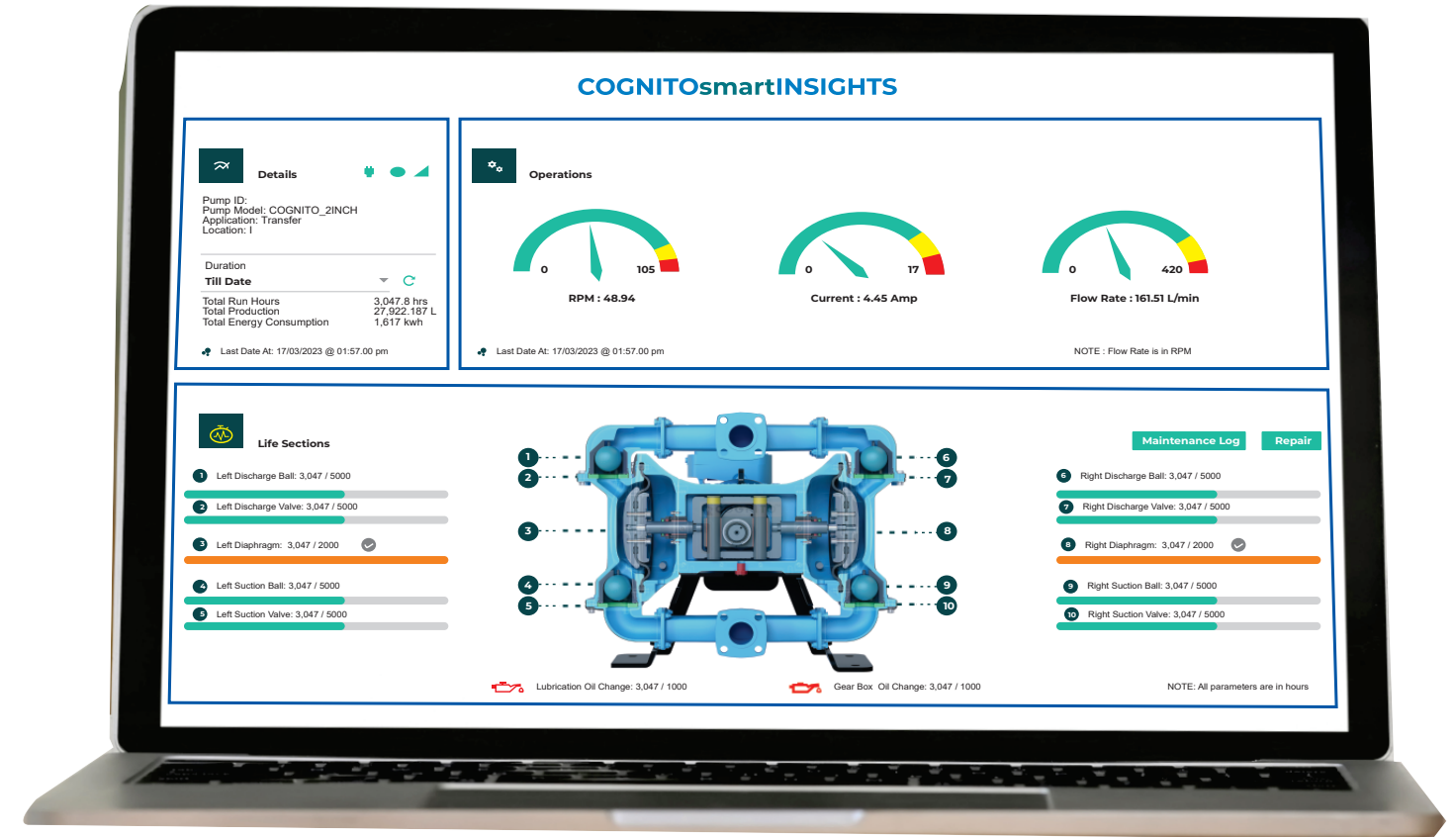

24x7 Real-Time Condition Monitoring

Preventive Maintenance Alerts

Central Reporting for All Department

Actionable insights

Secured Solution for Data Integrity

Remote Health Monitoring

COGNITOsMartiNSIGHTS, helps you connect, monitor, and analyse your equipment remotely and enables you to make better and faster decisions to optimize your equipment performance and improve overall process efficiency. Its advanced smart technology create an instant alert for any abnormality to enhance process.

Why Warren Rupp?



APPLICATIONS ENGINEERING, CUSTOMER SERVICE & AFTER SALES SUPPORT

From product selection, to troubleshooting, our team of experts are ready to help.



PRODUCT ENDURANCE LAB

Ensures product performance and drives product enhancements.



DEDICATED TEAM TO SUPPORT YOU!

Providing product expertise, personalized service, and after sales support.



GENUINE KITS AND PARTS

Provide guaranteed quality and ease of maintenance.

 **COGNITO™**

WARREN RUPP, INC.

Warren Rupp, Inc.
A Unit of IDEX Corporation
800 North Main Street
Mansfield, OH 44902 USA
Phone: 419.524.8388



Scan to learn more

Contact info.cognitopump@idexcorp.com for more information