

➤➤➤ **Service & Operating Manual (Pump Only)**

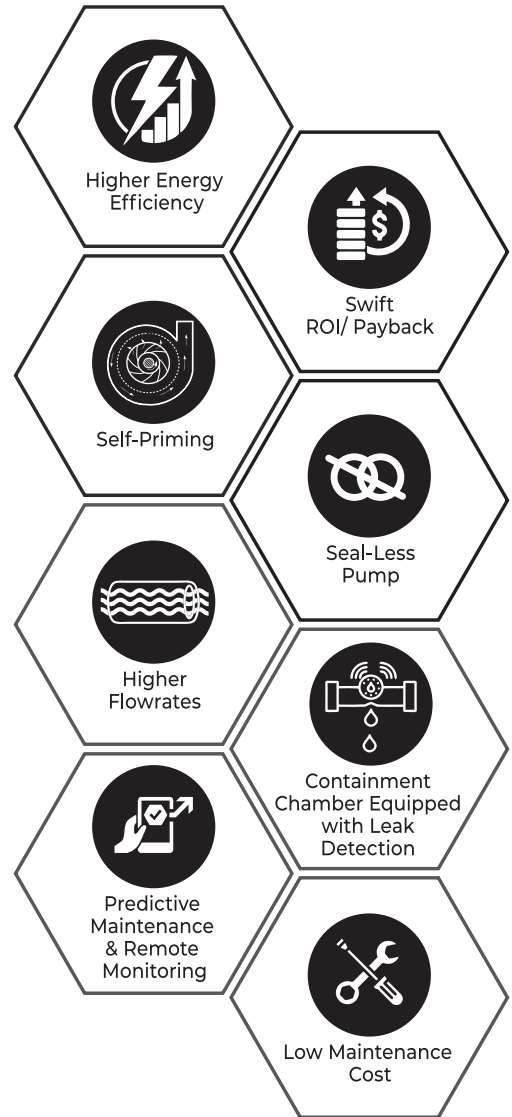

**North America Office (Warren Rupp, Incorporated):**

800 North Main Street Mansfield, Ohio 44902 | Tel: (419) 524-8388 | Email: [info.cognitopump@idexcorp.com](mailto:info.cognitopump@idexcorp.com)

**Manufacturing Plant (IDEX India PVT LTD):**

Survey No. 256, Near Bombardier Circle, GIDC Manjusr, Savli, Dist. Vadodara 391770, State Gujarat, India | Tel: 91-2667-662-001

**⚠ WARNING****INSTALLATION IN HAZARDOUS DUTY APPLICATIONS:**

Pumps that will operate in environments defined as “hazardous locations” must only be installed, connected and set-up by qualified personnel with knowledge and understanding of protection classes, regulations and provisions for apparatus in hazardous areas, for the region where the pump will operate, because these regulations and provisions, along with the definition of what constitutes hazardous areas vary by location.

**HAZARDOUS PRESSURE :**

Can result in serious injury or property damage. Do not service or clean pump, hoses or dispensing valve while the system is pressurized. Disconnect and lockout / tagout power supply to electric motor and VFD. Relieve pressure from the system by opening dispensing valve or device and / or carefully and slowly loosening and removing outlet hose or piping from pump.

**EXCESSIVE FLUID PRESSURE :**

Fluid pressure developed by the pump should not exceed the maximum pressure as stated on the pump model plate. Be sure material hoses and other components are able to withstand fluid pressures developed by this pump. Check all hoses for damage or wear.

**HAZARDOUS MATERIALS :**

Safe handling practices must comply with local and national laws and safety code requirements. Obtain Material Safety Data Sheets on all materials from the supplier for proper handling instructions. Check before sending pump to factory. Do not attempt to return a pump to the factory or service center that contains hazardous material

**EXPLOSION HAZARD:**

Models containing aluminum wetted parts cannot be used with Methylene Chloride, 1-1-1 -Trichloroethane or other Halogenated Hydrocarbon solvents. These may react and explode. Check all wetted parts to assure compatibility before using with process fluid.

**ELECTRIC SHOCK HAZARD :**

Pump must be grounded. Improper grounding, setup, or usage of the system can cause electric shock. Turn off and remove power before servicing or installing equipment. Connect only to grounded power source. All electrical wiring must be done by a qualified electrician and comply with all local codes and regulations.

**STATIC SPARK.**

1. Sparks can ignite flammable material and vapors & can cause explosion resulting in severe injury or death.
2. The pumping system must be grounded when it is pumping, flushing, recirculating or spraying flammable materials.
3. Secure pump, connections and all contact points to avoid vibration and generation of contact or static spark.
4. Comply to local building codes and electrical codes for specific grounding requirements.
5. After grounding, periodically verify continuity of electrical path to ground. Test with an ohmmeter from each component (e.g., hoses, pump, clamps, container, spray gun, etc.) to ground to ensure continuity. Ohmmeter should show 0.1 ohms or less.
6. Submerge the outlet hose end, dispensing valve or device in the material being dispensed if possible. (Avoid free streaming of material being dispensed.)
7. Use proper ventilation.



When used for toxic or aggressive fluids, the pump should always be flushed prior to disassembly.



Before maintenance or repair, shut off the motor and bleed the pressure from the pump. Be certain that approved eye protection and protective clothing are worn at all times. Failure to follow these recommendations may result in serious injury.

**⚠ CAUTION****CHEMICAL COMPATIBILITY :**

Check the chemical compatibility of the pump wetted parts and the substance being pumped, flushed or recirculated before using. Chemical compatibility may change with temperature and concentration of the chemical(s) within the substances being pumped, flushed or circulated. For specific fluid compatibility, consult the chemical manufacturer.

**HOT SURFACE :**

Precautions should be taken to restrict access to hot surfaces when needed. Metallic wetted sections can reach up to the same temperature as the fluid temperature (up to 100°C). Proper personal protective equipment (PPE) for hot surfaces should be worn. Check to ensure parts have cooled down sufficiently prior to any maintenance.

Do not use the pump for the structural support of the piping system. Ensure the system components are properly supported to prevent stress on the pump parts.

Ensure all operators of this equipment have been trained for safe working practices, understand it's limitations, and wear safety goggles / equipment when required.

Nonmetallic pumps and plastic components are not UV stabilized. Ultraviolet radiation can damage these parts and negatively affect material properties. Do not expose to UV light for extended periods of time.

Pressure relief valving or equivalent safeguards are required to prevent excess pressure on the discharge piping.

The pump is pressurized internally with pressure during operation. Make certain that all fasteners and piping connections are in good conditions and are reinstalled properly during reassembly.

Use safe practices when lifting.

**⚠ IMPORTANT**

Read the safety warnings and instructions in this manual before pump installation and start-up. Failure to comply with the recommendations stated in this manual could damage the pump and void factory warranty.

When the pump; is used for materials that tend to settle out or solidify, the pump should be flushed after each use to prevent damage. In freezing temperatures the pump should be completely drained between uses.

Torque all Fasteners before operation. Keep regular check. Creep of housing and gasket materials may cause fasteners to loosen. Torque all fasteners to ensure against fluid or air leakage.

<b>1.0 INTRODUCTION</b>	<b>4</b>	<b>8.0 INSTALLATION &amp; START-UP GUIDELINES</b>	<b>31</b>
<b>2.0 IMPORTANT WARNING &amp; CAUTIONS</b>	<b>5</b>	8.1 PUMP COMPONENTS.....	31
2.1 LIFTING & TRANSPORTATION .....	5	8.2 INSTALLATION GUIDELINES.....	32
2.2 STORAGE.....	5	8.3 PREREQUISITE BEFORE STARTING PUMP OPERATION .....	32
2.3 UNPACKING.....	5	8.4 TORQUE DETAILS FOR METALLIC PUMP.....	33
2.4 HEALTH & SAFETY .....	6	8.5 GROUNDING & PUMP EARTHING .....	34
2.5 QUALIFICATION OF PERSONNEL .....	6	8.5.1 PUMP EARTHING .....	34
2.6 CHEMICAL HAZARD .....	6	8.5.2 MOTOR GROUNDING .....	34
2.7 ELECTRIC HAZARD .....	6	<b>9.0 TROUBLESHOOTING</b>	<b>35</b>
2.8 TEMPERATURE HAZARD .....	6	<b>10.0 PREVENTIVE MAINTENANCE GUIDELINES</b>	<b>36</b>
2.9 GROUNDING THE PUMP .....	6	<b>11.0 MAINTENANCE GUIDELINES</b>	<b>38</b>
2.10 SAFETY DURING MAINTENANCE OR REPAIR	6	11.1 DIAPHRAGM REPLACEMENT.....	38
2.11 SPARE PARTS REPLACEMENT .....	6	11.2 BALL & SEAT CAGE REPLACEMENT .....	39
<b>3.0 TECHNICAL SPECIFICATIONS</b>	<b>7</b>	11.3 SEAL REPLACEMENT IN CENTER MECHANISM .....	39
3.1 OPERATING PRINCIPLE.....	7	11.4 SEAL REPLACEMENT FOR DAMPENER.....	39
3.2 MOTOR.....	8	11.5 DIAPHRAGM REPLACEMENT FOR DAMPENER.....	40
3.2.1 RECOMMENDED IEC AC MOTOR SPECIFICATION .....	8	11.6 DISPOSAL AFTER EXPIRATION OF THE EXPECTED LIFETIME.....	40
3.2.2 RECOMMENDED NEMA AC MOTOR SPECIFICATION .....	8	11.7 RESIDUAL RISKS .....	40
3.3 GEARBOX & SHAFT COUPLINGS .....	9	11.8 ACTIONS IN EMERGENCY.....	40
3.4 COGNITO PULSATION DAMPENER .....	10	11.9 IMPROVING PUMP’S LONGEVITY.....	40
3.5 PERFORMANCE CURVE .....	11	<b>12.0 CERTIFICATION</b>	<b>41</b>
3.6 MODEL CONFIGURATION.....	14	12.1 CERTIFICATION STANDARDS & MARKINGS .	41
3.7 NAME PLATE DETAILS.....	15	12.2 SPECIFIC CONDITION OF USE .....	41
3.7.1 STANDARD NAME PLATE DETAILS .....	15	<b>13.0 WARRANTY</b>	<b>42</b>
3.7.2 HAZARDOUS NAMEPLATE DETAILS .....	15		
<b>4.0 GENERAL ARRANGEMENT DRAWING</b>	<b>16</b>		
4.1 ALUMINUM (PUMP ONLY) .....	16		
4.2 STAINLESS STEEL (PUMP ONLY).....	16		
<b>5.0 EXPLODED VIEW WITH PARTS LIST</b>	<b>17</b>		
5.1 GENERAL EXPLODED VIEW.....	17		
5.2 COGNITO EODD ALUMINUM PUMP .....	19		
5.3 COGNITO EODD SS PUMP .....	23		
5.4 DIAPHRAGM ASSEMBLY EXPLODED VIEW ..	27		
<b>6.0 VARIABLE FREQUENCY DRIVE (VFD)</b>	<b>28</b>		
<b>7.0 LEAK DETECTION SENSOR ASSEMBLY</b>	<b>29</b>		
7.1 LEAK DETECTION SENSOR ASSEMBLY: SAFE AREA APPLICATION (NON-HAZARDOUS LOCATION) .....	29		
7.2 LEAK DETECTION SENSOR ASSEMBLY: HAZARDOUS AREA APPLICATION (ATEX / IECEx).....	30		

Cognito is a brand of IDEX Corporation which is committed to offer highly engineered products and services to solve customer critical problems and to meet their future expectations.

Cognito pumps are Smart IoT capable Electrically Operated Double Diaphragm Pumps designed with a robust mechanism to satisfy every customer's demands for increased production efficiency & to lower total cost of ownership while facilitating smooth handling of variety of fluids & slurries. With proper attention to installation & maintenance, Cognito EODD pumps will give efficient and trouble-free operation.

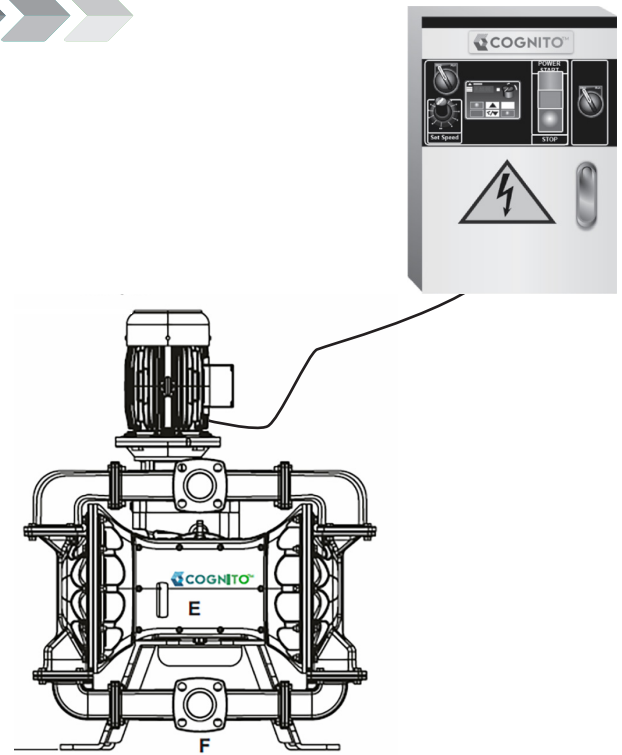

Read the safety warnings & instructions in this manual before pump installation and start-up. One must strictly follow the IOM manual to avoid injury and hazards which may occur otherwise. Failure to comply with the recommendations stated in this manual could damage the pump and void factory warranty. In case any instruction in this manual is unclear or any information is missing, please contact customer service at Warren Rupp, Inc.

**Read, Understand and Follow this information on to avoid injury and Property Damage / Pump Damage.**

### 2.1 Lifting & Transportation

Follow below instructions to move the EODD pump to the required location:

1. The pump is provided with two lifting hooks as shown in Figure 1.
2. Lift the pump only from these two points
3. Lifting the pump from any other points may cause damage to the pump as well as injury to the person
4. While relocating the pump, make sure to decouple from the pipeline only after releasing the pressure & disconnecting the power supply.
5. Ensure adequate clearance around the pump for sufficient access and ventilation.

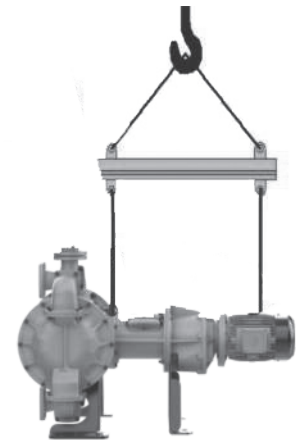

Figure 1

### 2.2 Storage

If the equipment is to be stored prior to installation, follow below instruction

1. EODD pumps should be flushed with the compatible media and should be stored in a dry & dust free location protected from impacts and vibrations. Storage temperature should be in between 15°C (59°F) to 35°C (95°F) & relative humidity below 70%.
2. Do not remove the protective covers from the pump before use.
3. In case of long-term storage, consult customer service

### 2.3 Unpacking

After you unpack the pump, and before you use it for the first time, follow below instruction

1. Check if the information on the nameplate correspond to the ordered pump configuration.
2. Make sure all parts and accessories listed on the packing list are as per the ordering.
3. Check for any damage which may be caused by inappropriate handling during shipment.
4. Immediately report out any damage or material shortage to the transport company and to the manufacturer.

Before pump operation, inspect all gaskets and fasteners for any looseness caused due to gasket creep. Re-torque loose fasteners to prevent leakage.

## **2.4 Health & Safety**

The pumps are designed to handle different applications. Do not use the pump on the application / media different from that for which it was ordered without consulting the manufacturer.

The pumps are tested with water at our facility. If your pumped product has the chances to react with water, please make sure the pump is completely dry before operation.

## **2.5 Qualification of personnel**

The personnel in charge of the installation, commissioning and maintenance of the EODD pumps should be qualified, experienced and authorized personnel. The safety of people, animals and property must be ensured while handling these pumps.

## **2.6 Chemical hazard**

Verify the chemical compatibility of the pump wetted parts and the substance being pumped, flushed or recirculated. For specific fluid compatibility, consult customer service. Whenever the pump is to be used for pumping a different fluid, it is essential to clean the pump beforehand in order to avoid any possible reaction between the two products.

When used for toxic or aggressive fluids, the pump should always be flushed prior to disassembly. User must ensure chemical compatibility, and any pressure / temperature limits are not exceeded. If pump is not used for long period, care must be taken when restarting. If in any doubt, remove pump from line and flush with a suitable cleaner. Solidified deposits within the pump may cause damage to the diaphragms.

## **2.7 Electric hazard**

Do not carry out any maintenance or/and operation on the pump while it is in operation. Check the specification of power supply before operation.

## **2.8 Temperature hazard**

While operating the pump, the mechanical parts and the gear-motor surface temperature should not exceed nominal working temperatures stated by the gear-motor manufacturer.

## **2.9 Grounding the pump**

Take action to prevent static sparking. Fire or explosion can result, especially when handling flammable liquids. Make sure pump is grounded by connecting the earthing wire to the motor housing.

## **2.10 Safety during maintenance or repair**

Before maintenance or repair, switch off the power. Shut off the compressed air lined, bleed all pressure, and disconnect the air line to the dampener. Wear protective clothing and safety goggles when operating and /or working in the vicinity of Cognito Pump. Failure to follow these recommendations may result in serious injury.

## **2.11 Spare parts replacement**

The use of non-OEM replacement parts will void agency certifications and warranty clause. We recommend to use only OEM replacement parts

### 3.1 Operating Principle

Cognito Electrically Operated Double Diaphragm pumps are highly engineered Pumps designed for various industrial application considering energy efficiency, safety, reliability, easy to use, maintenance friendly & long-lasting life.

The pump is driven by an electric motor with a reduction gearbox. This in turn drives an eccentric shaft to operate the Diaphragms. When the eccentric shaft rotates and reaches peak on one side, example right side of the chamber, at the same time left side of the chamber reaches valley. This causes extrusion of right diaphragm and intrusion of left diaphragm. As a result positive pressure is built on right side (green) and vacuum on the left side (blue).

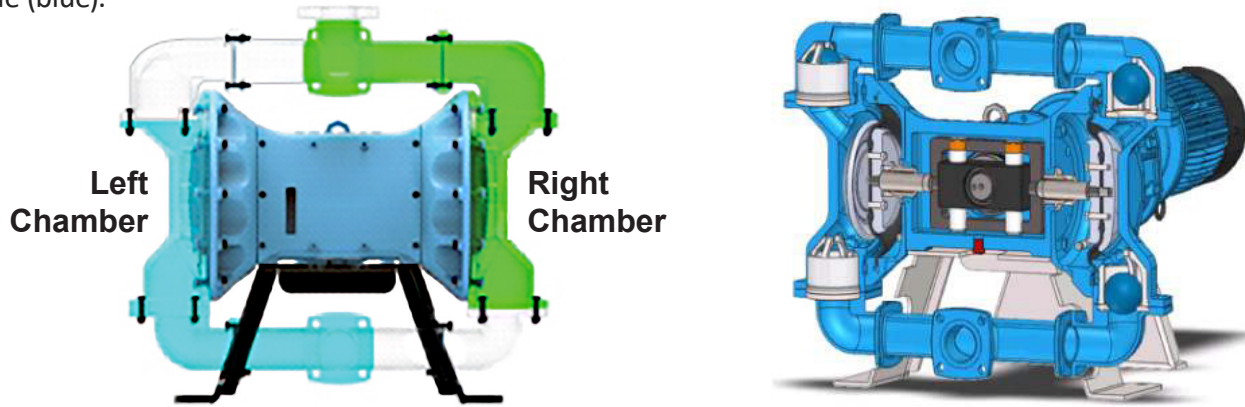

Figure 2: Working Mechanism

Cognito EODD	4" (101mm)	3" (76mm)	2" (50mm)
Operation	Electric		
Maximum Flow Rate: GPM (LPM)	211 (800)	135 (510)	79 (300)
Maximum Operating Pressure: PSI (BAR)	87 (6)	116 (8)**	116 (8)
Pump Only Weights	AL. 903 lbs. (410 kg) SS 1,014 lbs. (470 kg)	AL. 485 lbs. (220 kg) SS 573 lbs. (260 kg)	AL. 242 lbs. (110 kg) SS 297 lbs. (135 kg)
Pump Body	Aluminum or Stainless Steel		
Diaphragm & Check Ball	Neoprene#, Santoprene, or PTFE		
Maximum Suction Lift: FT (M)*	26' (8) Wet	26' (8) Wet	26' (8) Wet
	18' (5.5) Dry	16' (5.1) Dry	13.5' (4.1) Dry
Solids Handling: IN (MM)	.35" (9mm)	.27" (7mm)	.19" (5mm)
Motor & Gear Box: HP	10hp	7.5hp	5hp
Sound Level	<80 db		
Displacement Per Stroke: GAL (L)	1.25 (4.75)	.76 (2.9)	.39 (1.48)

\* Applicable for Santoprene & PTFE Diaphragm only. \*\* with reduced stroke length, consult customer service. # Not available for 2" pump.

Maximum Temperature Limits	Min.	Max.
Ambient Temperature	-20°C (-4°F)	55°C (131°F)
Process Fluid Temperature	-10°C (-14°F)	120°C (248°F)
Fluid Temperature should be further limited for the following material of Diaphragm used in the wetted sections:		
Neoprene	-10°C (-14°F)	77°C (170°F)
Santoprene	-10°C (-14°F)	92°C (197°F)
PTFE	-10°C (-14°F)	120°C (248°F)

**Warning**

1. Maximum fluid temperature as specified in above table should never be exceeded to maintain hazardous area surface temperature nameplate rating.
2. Do not allow fluids to freeze inside the pump.

**Note:** Santoprene® is a registered trademark of Celanese

## 3.2 Motor

### 3.2.1 Recommended IEC AC Motor Specification

Type	3Phase   AC Induction Motor
Rating	5 hp (3.7 kW)   7.5 hp (5.5 kW)   10 hp (7.5 kW)
Pole	4 POLE
RPM	~1450 at 50 Hz or ~1750 at 60 Hz
EFF Level	IE3
Frame Size	IEC 112M (5 hp)   IEC 132S (7.5 hp)   IEC 132M (10 hp)
Drive	VFD (Inverter) capable recommend
Power Supply	>200 V, 3 Phase, 50 or 60 Hz
Motor Enclosure	TEFC or as the motor manufacturer recommends per application
Application Area	SAFE (Non-Hazardous Environments)
Type of Protection	IP55
Temperature	Amb 50 °C
Insulation Class	F
Mounting	Flange or Face (must match Gearbox interface)
TB Position	AS PER MFG. STANDARD
Lifting	2X Lifting Eye Casted or Fitted

### 3.2.2 Recommended NEMA AC Motor Specification

Type	3Phase   AC Induction Motor
Rating	5 hp (3.7 kW)   7.5 hp (5.5 kW)   10 hp (7.5 kW)
Pole	4 POLE
RPM	~1450 at 50 Hz or ~1750 at 60 Hz
EFF Level	NEMA Premium or IE3
Frame Size	NEMA 184T (5 hp)   NEMA 213T (7.5 hp)   NEMA 215T (10 hp)
Drive	VFD (Inverter) capable recommend
Power Supply	>200 V, 3 Phase, 50 or 60 Hz
Motor Enclosure	TEFC or as the motor manufacturer recommends per application
Application Area	SAFE (Non-Hazardous Environments)
Type of Protection	IP55
Temperature	Amb 50 °C
Insulation Class	F
Mounting	Flange or Face (must match Gearbox interface)
TB Position	AS PER MFG. STANDARD
Lifting	2X Lifting Eye Casted or Fitted

Consult motor manufacturer for recommendations with AC motor specifications in hazardous environments (explosive or fire) or DC motor specification per the end user application.



### 3.3 Gearbox & Shaft Couplings

Recommended Gearbox Specification	
Type	Inline Helical   Bevel Helical
Rating	5 hp (3.7 kW)   7.5 hp (5.5 kW)   10 hp (7.5 kW)
Output Shaft Mounting	Single Solid Shaft   B5 Flange Mounted
Input Configuration	Metric IEC Motor Ready Input
Motor Mounting	Flange or Face (must match AC Motor)
Motor Mount at Gearbox (5   7.5   10 hp)	IEC 112M or NEMA 184T   IEC 132S or NEMA 213T   IEC 132M or NEMA 215T
Drain Plug Position	Bottom of Body
Filling Plug Position	Top of Body
Oil Grade	ISO VG 320 Mineral Oil
Service Factor	1.5 minimum (reciprocating pump loading)
Minimum Torque Capacity Rating	560 Nm (2" pump)   900 Nm (3" pump)   1550 Nm (4" pump)
Output Speed when using VFD with Motor	Pump Size & SPM (RPM)   2" - 115   3" - 92   4" - 92
Lifting Point	1x Lifting Eye Casted or Fitted

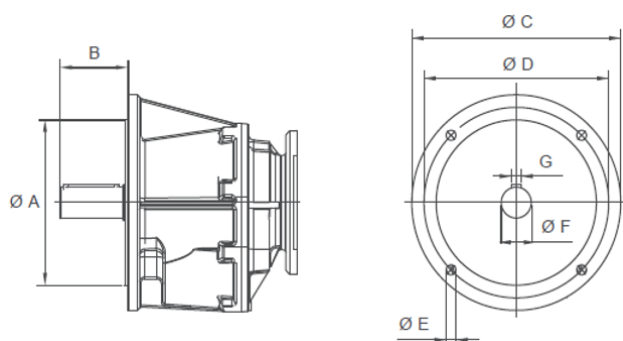

Pump Size	Recommend Gearbox Type	Ø A	B min.	B max.	Ø C	Ø D	Ø E	Ø F min.	G min.
2" 5 HP Inline	Helical	180	70	90	250	215	13.5	35	14
2" 5 HP Vertical	"Helical-Bevel (Right Angle)"		65					50	
3" 7.5 HP Inline	Helical	230	90	100	300	265	13.5	14	45
3" 7.5 HP Vertical	"Helical-Bevel (Right Angle)"		85	120				60	18
4" 10 HP Inline	Helical		65	14				55	16
4" 10 HP Vertical	"Helical-Bevel (Right Angle)"	250	65	115	350	300	17.5	70	20

All Dimensions in Millimeters



Pump Size	Recommend Shaft Coupling Type	Required Spider Torque Rating	Reference Pump Shaft Dimensions	Shaft Coupling Outer Diameter max.	Shaft Coupling Total Length max.
			Diameter x Keyway Width		
2" 5 HP	Flexible (Elastomeric)	"560 Nm (413 ft-lb)"	Ø40x14	140	140
3" 7.5 HP	Flexible (Elastomeric)	"900 Nm (664 ft-lb)"	Ø50x16	160	180
4" 10 HP	Flexible (Elastomeric)	"1550 Nm (1143 ft-lb)"	Ø50x16	160	215

All Dimensions in Millimeters

### 3.4 Cognito Pulsation Dampener

Pulsation Dampener plays a very important role in Positive Displacement Pumps to reduce pulsations & vibrations during pump operation, thus ensuring continuous & precise non-pulsed flow rate.

Cognito Dampeners are designed to provide vibration free smooth continuous flow that makes this component a suitable equipment for safeguarding the system.

It maintains a constant volume of air support at diaphragm by automatically adjusting to the current pressure and thereby absorbing the pulse.

#### Working Principle

A pulsation dampener uses a flexible diaphragm to separate a liquid chamber from a compressed air chamber. A rod connected to the center of the diaphragm activates the air inlet and exhaust which automatically admits or exhausts air to the air chamber. This maintains the diaphragms in mid-range of stroke to eliminate flow pulsation & pressure spikes.

Cognito Dampeners are suitable for EODD pump models and are available in Aluminum and Stainless-steel wetted housings.

Recommended Air Inlet Pressure : 1 bar higher from the Discharge Pressure



### COGNITO DAMPENER PERFORMANCE: Dampening 90+% for all the sizes

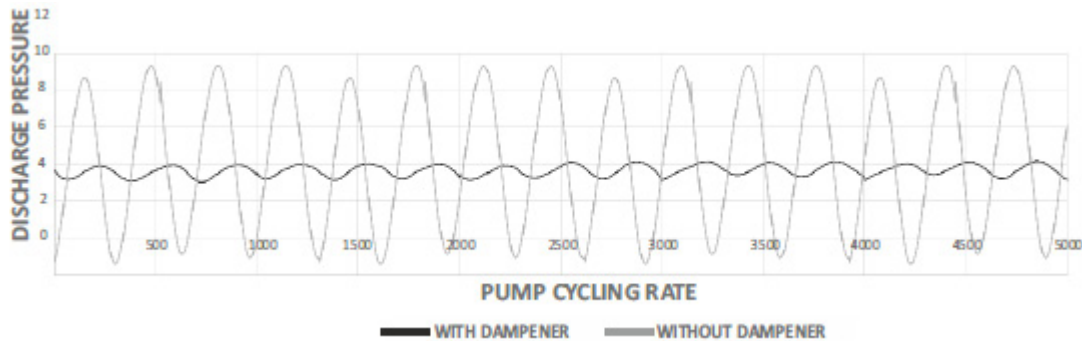

Technical Specs				Available Wetted Materials				
				Wetted Parts			Diaphragm	
Dampener Size	Compatible Pump Size	Air Inlet Size	Max. Pressure	AI	SS	PP	Santoprene	Santoprene PTFE Overlay
2"	1.5"	1/8" NPT	8 bar	Yes	Yes	Contact Customer Service	Yes	Yes
2"	2"	1/8" NPT	8 bar	Yes	Yes	Contact Customer Service	Yes	Yes
3"	3"	1/8" NPT	8 bar	Yes	Yes	Contact Customer Service	Yes	Yes
3"	4"	1/8" NPT	8 bar	Yes	Yes	Contact Customer Service	Yes	Yes

Consult the product manual for more information.

### 3.5 Performance Curve

#### Cognito 2" EODD Pump

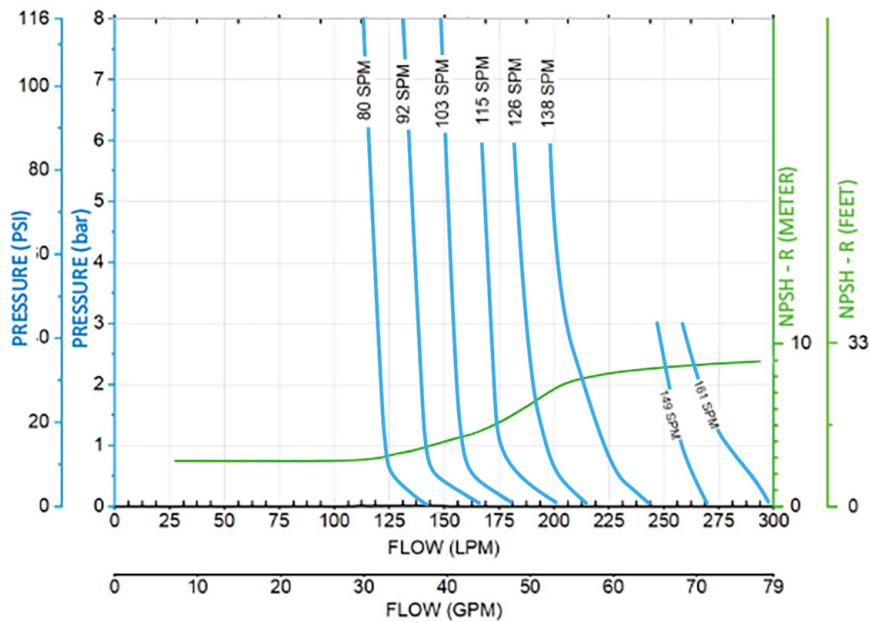

#### Notes :

1. Use 5 hp / 3.7 kW motor with VFD
2. For SPM 161 & 149, contact Warren Rupp
3. The performance curve is based on following: SANTOPRENE elastomer fitted pump, flooded suction, water at ambient conditions 25°C, with COGNITO Dampener
4. The performance result may deviate in excess of 5% based on elastomer.
5. Performance vary based on Viscosity
6. NPSH-R curve at 6 bar Max. discharge condition

## Cognito 3" EODD Pump

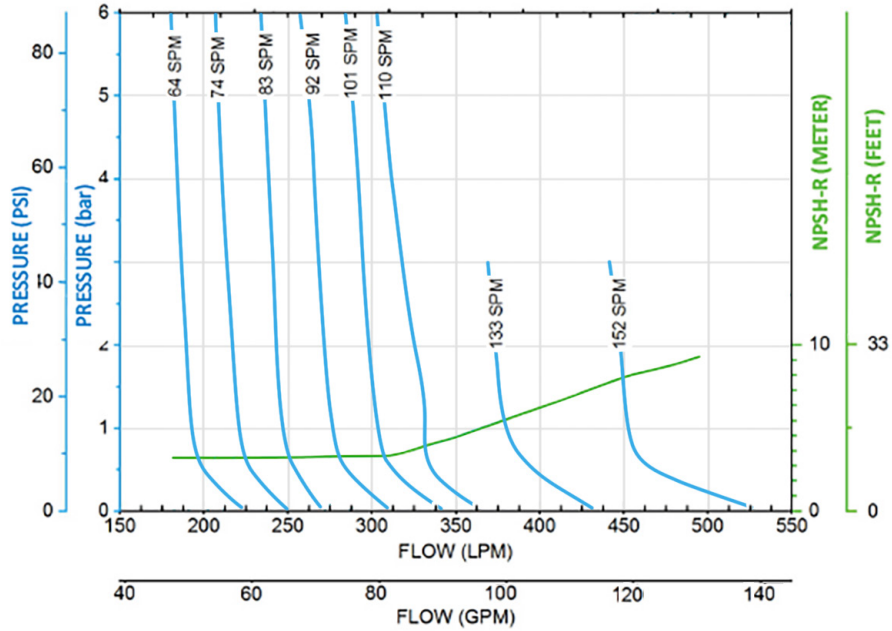

### Notes :

1. Use 7.5 hp / 5.5 kW motor with VFD
2. For SPM 152 & 133, contact Warren Rupp
3. The performance curve is based on following: SANTOPRENE elastomer fitted pump, flooded suction, water at ambient conditions 25°C, with COGNITO Dampener
4. The performance result may deviate in excess of 5% based on elastomer.
5. Performance vary based on Viscosity
6. NPSH-R curve @6bar Max. discharge condition

## Cognito 4" EODD Pump

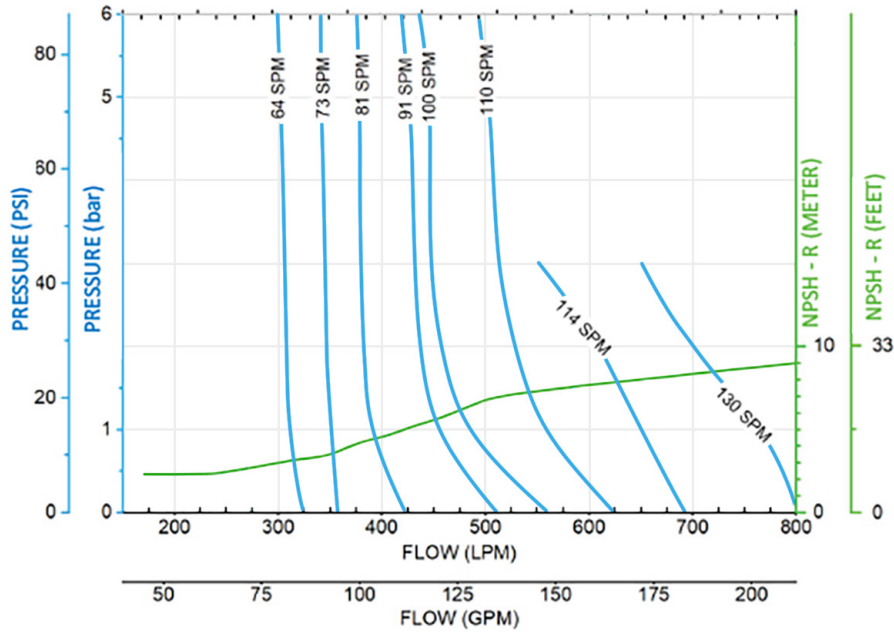

### Notes :

1. Use 10 hp / 7.5 kW motor with VFD
2. For SPM 130 & 114, contact Warren Rupp
3. The performance curve is based on following: SANTOPRENE elastomer fitted pump, flooded suction, water at ambient conditions 25°C, with COGNITO Dampener
4. The performance result may deviate in excess of 5% based on elastomer.
5. Performance vary based on Viscosity
6. NPSH-R curve @6bar Max. discharge condition

### 3.6 Model Configuration

COGNITO EODD CODE LOGIC		PUMP																			
		1	2	3	4	5	6,7	8	9	10	11	12	13	14	15	16	17	18	19	20	
NOTE: CHANGES TO THIS DOCUMENT CAN ONLY BE MADE BY SALES / APPLICATION		PUMP TYPE	WETTED PARTS	PUMP SIZE	PUMP SPM	GEARBOX MOUNTING	MOTOR RATING	DIAPHRAGMS	CHECK BALL VALVE	CHECK VALVE SEAT	INSERT	LEAK SENSOR	GEARBOX MAKE	MOTOR MAKE	STARTER	STARTER MAKE	CONNECTIVITY	SAFETY SWITCH	MOTOR TYPE	EXTRA-1	
*Note: Limited offerings, consult customer service.																					E
E	EODD	POSITION 1: PUMP TYPE																			
A	ALUMINUM																				
S	STAINLESS STEEL	POSITION 2: WETTED PARTS																			
P	POLYPROPYLENE*																				
4	4 INCH																				
3	3 INCH																				
2	2 INCH	POSITION 3: PUMP SIZE																			
5	1.5 INCH (PP ONLY)																				
H	>90 RPM	POSITION 4: PUMP SPM																			
V	VERTICAL																				
I	INLINE (HORIZONTAL)	POSITION 5: GEARBOX MOUNTING																			
10	10hp   7.5kW																				
07	7.5hp   5.5kW	POSITION 6,7: MOTOR RATING																			
05	5hp   3.7kW																				
N	NEOPRENE*																				
S	SANTOPRENE	POSITION 8: DIAPHRAGMS																			
P	PTFE																				
N	NEOPRENE																				
S	SANTOPRENE	POSITION 9: CHECK BALL VALVE																			
P	PTFE																				
N	NEOPRENE																				
T	SANTOPRENE																				
S	STAINLESS STEEL	POSITION 10: CHECK VALVE SEAT																			
L	POLYPROPYLENE*																				
P	PTFE																				
C	STOPPER CAGE (ONLY ALU. WETTED)																				
P	PP CAGE (ONLY PP WETTED)*	POSITION 11: INSERT																			
0	NOT APPLICABLE (ONLY SS WETTED)																				
C	CONDUCTIVE TYPE																				
A	ATEX & HAZLOC CERTIFIED	POSITION 12: LEAK SENSOR																			
0	NOT APPLICABLE																				
0	NOT INCLUDED, CUSTOMER TO SUPPLY	POSITION 13: GEARBOX MAKE																			
0	NOT INCLUDED, CUSTOMER TO SUPPLY	POSITION 14: MOTOR MAKE																			
0	NOT INCLUDED, CUSTOMER TO SUPPLY	POSITION 15: STARTER																			
0	NOT INCLUDED, CUSTOMER TO SUPPLY	POSITION 16: STARTER MAKE																			
0	NOT APPLICABLE	POSITION 17: CONNECTIVITY																			
0	NOT INCLUDED	POSITION 18: SAFETY SWITCH																			
A	ATEX CERTIFIED																				
S	SAFE AREA (NON-HAZARDOUS ENVIRONMENTS)	POSITION 19: MOTOR TYPE																			
0		POSITION 20: EXTRA-1 / CONSULT WARREN RUPP																			

### 3.7 Name Plate Details

#### 3.7.1 Standard Name Plate Details



## EODD Pump

Model No.:

Serial No.:

Max Speed.:



Lubrication Oil Details:

Rated Power:

Rated Head Pressure:

Month of MFG:



Trusted Solutions,  
Improving Lives™

#### 3.7.2 Hazardous Nameplate Details





## EODD Pump

Model No.:

Sr. No.:

T Ambient:  Rated Power:

 II 2 G D  
 Ex h ia IIC T6-T3 Gb (with sensor)  
 Ex h IIC T6-T3 Gb (without sensor)  
 Ex h ia IIIC T85-T150 Db (with sensor)  
 Ex h IIIC T85-T150 Db without sensor

 IECEX DNV 23.0077X  
 DNV 23 ATEX 33382X  
 DNV 24 UKEX 33383X

Process Temp.  

T. Class

Warnings  
Potential Electrostatic Charging Hazard  
- See Instructions

  
**Manufacturer's Detail**  
 IDEX India Pvt. Ltd.  
 Survey No.256, GIDC Manjusar, Savli,  
 Vadodara, 391770 Gujarat, India

#### Definition:

1. Pump Model: Configured Pump Model Number
2. Serial No.: Pump Serial No.
3. Max. Speed: Pump RPM
4. Lubrication Oil: Pump Lubricating Oil Grade & Qty.
5. Rated Power: Motor Rated Power
6. Rated Head: Pump Max. Discharge Pressure / head
7. Month of MFG: Manufacturing Month & Year
8. T. Ambient: Allowable Ambient Temperature
9. Process Temp.: Allowable process fluid temperature range
10. T. Class: Temperature Class of the Equipment at process fluid temperature
11. Manufacturer's location & details

#### Pump's Temperature Class is Based on the Process Fluid Temperature

PROCESS FLUID TEMPERATURE	TEMPERATURE CLASS OF THE PUMP	
	GAS	DUST
-10°C to +120°C	T3	150°C
-10°C to +105°C	T4	135°C
-10°C to +100°C	T4	130°C
-10°C to +90°C	T4	120°C
-10°C to +70°C	T5	100°C
-10°C to +65°C	T5	95°C
-10°C to +55°C	T6	85°C

4.1 Aluminum (Pump Only)

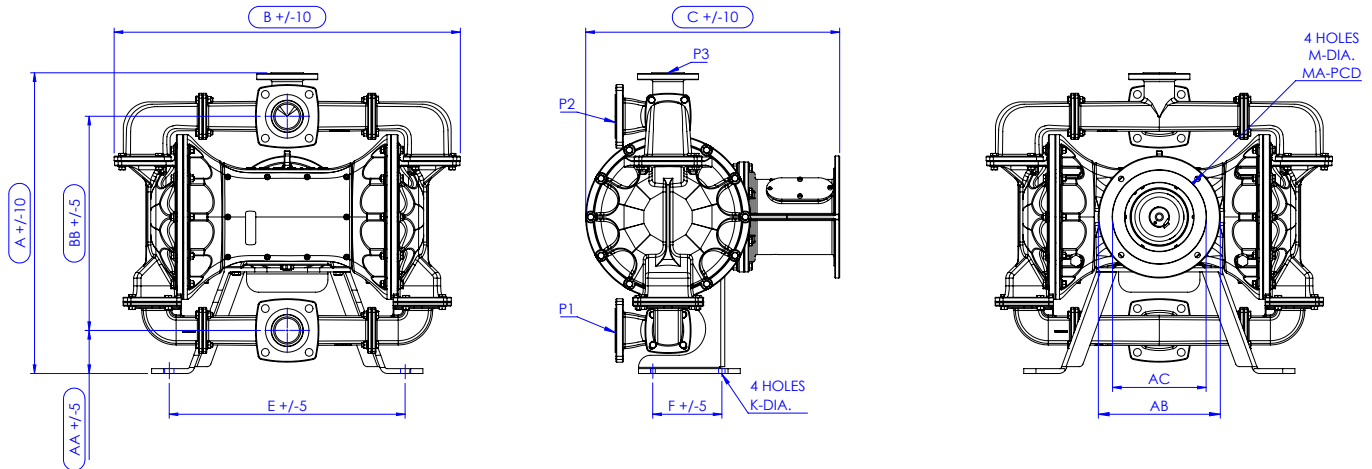

Pump Size	Rating	Motor Orientation	Foot Print			Floor Anchoring			Gearbox Interface				Inlet (Suction) / Outlet (Discharge) Ports				
			A	B	C	E	F	K	AB	AC	M	MA	P1	P2	P3	AA	BB
4"	10 HP (7.5 KW)	Horizontal	830	1010	776	650	250	18	300	230 X 5	13.5	265	4" 150# ANSI 16.5 FLANGE	4" 150# ANSI 16.5 FLANGE	3" 150# ANSI 16.5 FLANGE	118	632
		Vertical							350	250 X 5	17.5	300					
3"	7.5 HP (5.5 KW)	Horizontal	700	840	625	580	170	18	300	230 X 5	13.5	265	3" 150# ANSI 16.5 FLANGE	3" 150# ANSI 16.5 FLANGE	3" 150# ANSI 16.5 FLANGE	106	527
		Vertical															
2"	5 HP (3.7 KW)	Horizontal	600	735	500	480	130	16	250	180 X 4	13.5	215	2" 150# ANSI 16.5 FLANGE	2" 150# ANSI 16.5 FLANGE	2" 150# ANSI 16.5 FLANGE	95	420
		Vertical															

4.2 Stainless Steel (Pump Only)

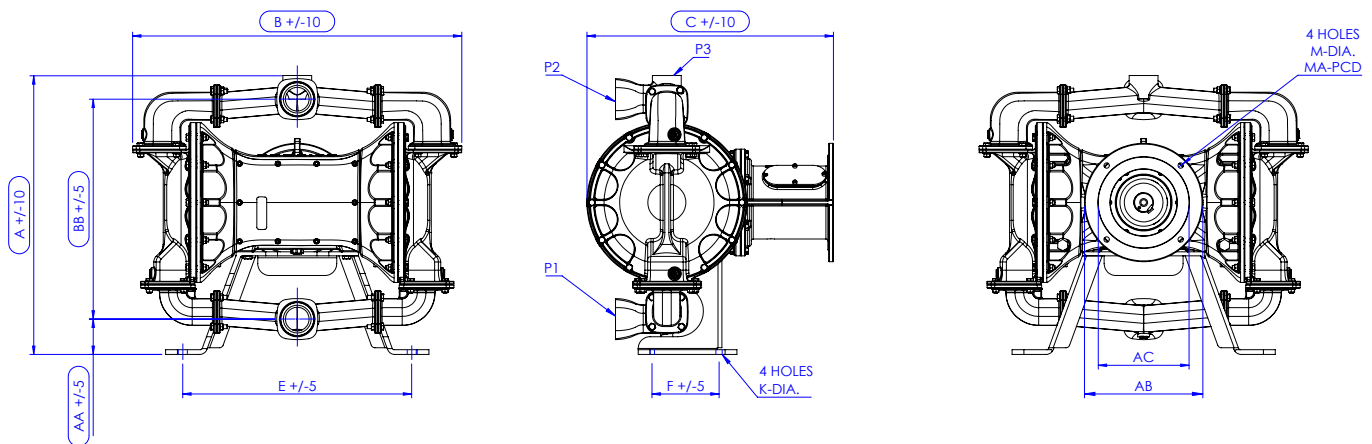

Pump Size	Rating	Motor Orientation	Foot Print			Floor Anchoring			Gearbox Interface				Inlet (Suction) / Outlet (Discharge) Ports				
			A	B	C	E	F	K	AB	AC	M	MA	P1	P2	P3	AA	BB
4"	10 HP (7.5 KW)	Horizontal	837	1017	776	650	250	18	300	230 X 5	13.5	265	4" BSP	4" BSP	3" ANSI FLANGE	100	668
		Vertical							350	250 X 5	17.5	300					
3"	7.5 HP (5.5 KW)	Horizontal	707	834	625	580	170	18	300	230 X 5	13.5	265	3" NPT	3" NPT	3" ANSI FLANGE	90	557
		Vertical															
2"	5 HP (3.7 KW)	Horizontal	569	737	500	480	130	16	250	180 X 4	13.5	215	2" NPT	2" NPT	2" ANSI FLANGE	80	449
		Vertical															



5.1 General Exploded View

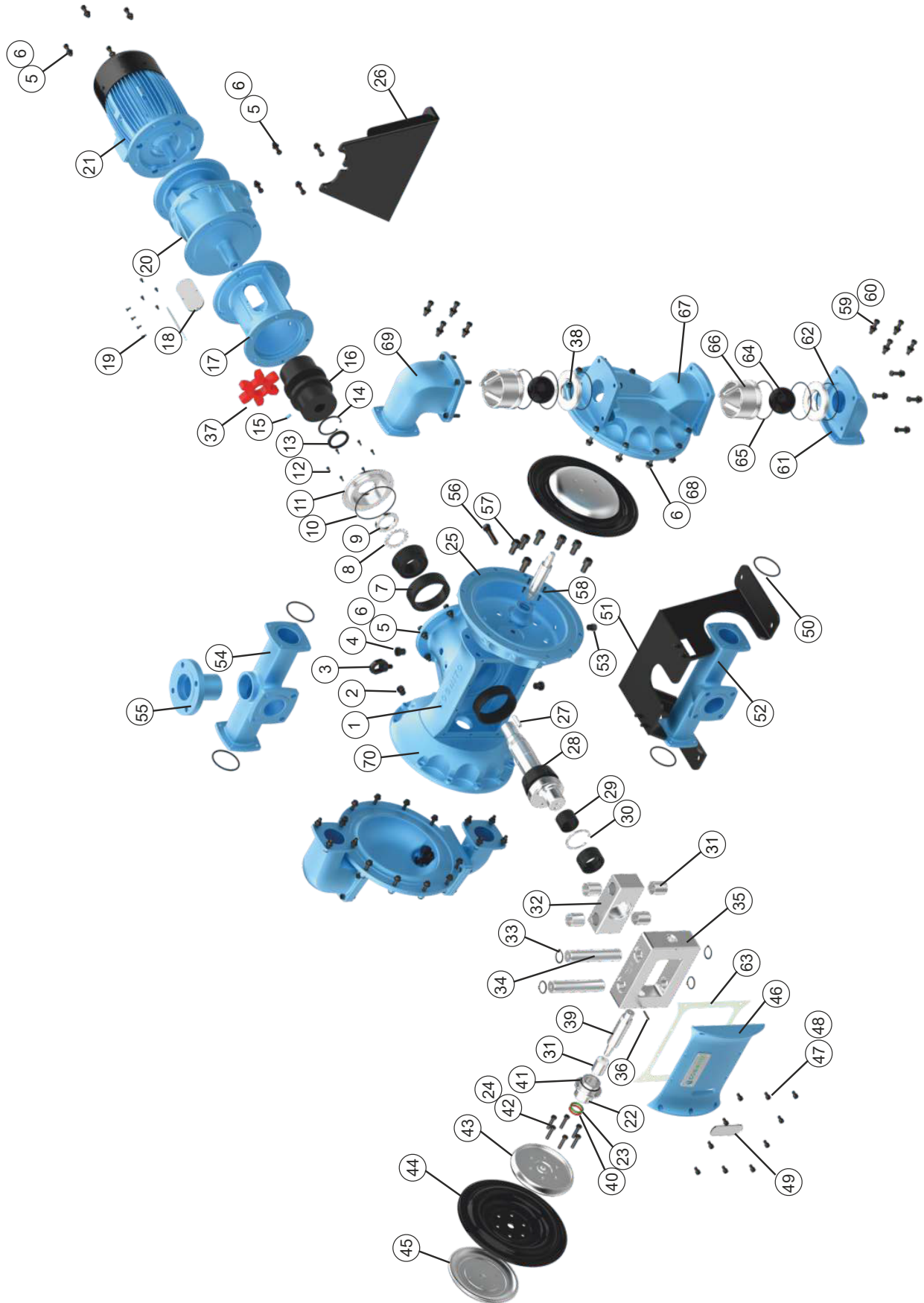

## Composite Part Identification

Item	Description	QTY
1	INTEGRATED CENTRE CONSOLE	1
2	VENT PLUG	2
3	LIFTING EYE-BOLT	1
4	OIL PLUG	2
5	HEX HEAD BOLT	14
6	HEX NUT	54
7	TAPPER ROLLER BEARING	2
8	LOCK WASHER IS-6731	1
9	LOCK NUT IS-6731	1
10	OIL SEAL CAP O-RING	1
11	OIL SEAL CAP	1
12	HEX HEAD BOLT	6
13	SHAFT SEAL	1
14	CIRCLIP INTERNAL IS-3075	1
15	COUPLING SET SCREW	2
16	JAW COUPLING, CONSULT CUSTOMER SERVICE	1
17	COUPLING HOUSING	1
18	COUPLING SIGHT GLASS	2
19	SIGHT GLASS, CAP SCREW	8
20	GEARBOX EXCLUDED, REFERENCE ONLY	1
21	ELECTRIC MOTOR EXCLUDED, REFERENCE ONLY	1
22	SEAL SLEEVE	2
23	ROD SEAL	2
24	LOCK WASHER, DIAPHRAGM	12
25	BACK CHAMBER LHS	1
26	GEARBOX SUPPORT	1
27	KEY, SHAFT	1
28	CRANKSHAFT, PUMP	1
29	NEEDLE BEARING	1
30	CIRCLIP INTERNAL IS-3075	1
31	BUSH BEARING	6
32	YOKE	1
33	CIRCLIP EXTERNAL IS-3075	4
34	YOKE PIN	2
35	CARRIAGE	1

Item	Description	QTY
36	SET SCREW, CARRIAGE	2
37	SOFT SPIDER, COUPLING	1
38	CHECK VALVE SEAT	4
39	CONNECTING ROD, DIAPHRAGM	2
40	WIPER SEAL	2
41	O-RING, SEAL SLEEVE	2
42	HEX HEAD BOLT, DIAPHRAGM	12
43	PISTON PLATE	2
44	DIAPHRAGM	2
45	DIAPHRAGM PLATE	2
46	COVER PLATE	1
47	BOLT, COVER PLATE	10
48	SPRING WASHER, COVER PLATE	10
49	SIGHT GLASS, COVER PLATE	1
50	O-RING, MANIFOLD	4
51	PUMP SUPPORT	1
52	MANIFOLD SUCTION	1
53	DRAIN PLUG, BACK CHAMBER	2
54	MANIFOLD DISCHARGE	1
55	MANIFOLD SPOOL	1
56	SENSOR	2
57	BOLT, BACK CHAMBER	14
58	BOLT, SEAL SLEEVE	8
59	BOLT, MANIFOLD	32
60	NUT, MANIFOLD	32
61	ELBOW SUCTION	2
62	O-RING, CHECK VALVE SEAT	8
63	GASKET, COVER PLATE	1
64	CHECK BALL VALVE	4
65	O-RING, STOPPER CAGE (ALU. PUMP)	4
66	STOPPER CAGE (ALU. PUMP)	4
67	WET-CHAMBER	2
68	HEX HEAD BOLT, WET-CHAMBER	20
69	ELBOW DISCHARGE	2
70	BACK CHAMBER RHS	1



## COGNITO EODD-2", ALUMINUM PARTS

Item	Part No.	Description	QTY
1	88940020	MANIFOLD DISCHARGE, ALUMINUM	1
2	88940021	ELBOW DISCHARGE, ALUMINUM	2
3	88940016	WET-CHAMBER, ALUMINUM	2
4	88940017	DIAPHRAGM PLATE, ALUMINUM	2
5	88940044	OVERLAY DIAPHRAGM, SANTOPRENE	2
	88940039	OVERLAY DIAPHRAGM, PTFE (WITH 88940044)	2
6	88940045	BACKUP DIAPHRAGM, SANTOPRENE	2
7	88940040	SOFT WASHER, PTFE	2
8	88940037	PISTON PLATE, WCB	2
9	88940019	DIAPHRAGM ROD	2
10	88940015	SEAL SLEEVE, STAINLESS STEEL	2
11	88940024	ELBOW SUCTION, ALUMINUM	2
12	88940013	PUMP BASE	1
13	88940014	GEARBOX SUPPORT 5HP INLINE (AS35)	1
	88940035	GEARBOX SUPPORT 5HP VERTICAL (BK 40)	1
14	26640028	CONDUCTIVE SENSOR	2
15	88940023	MANIFOLD SUCTION, ALUMINUM	1
16	88940011	BACK CHAMBER RHS	1
17	88940001	CENTRE CONSOLE	1
18	88940012	BACK CHAMBER LHS	1
19	88940027	STOPPER CAGE	4
20	88940041	CHECK BALL VALVE, SANTOPRENE	4
	88940042	CHECK BALL VALVE, PTFE	4
21	88940022	CHECK VALVE SEAT, S.S	4
	88940043	CHECK VALVE SEAT, PTFE	4
22	26640016	WIPER SEAL	2
23	26640017	ROD SEAL	2
24	26640018	O-RING, SEAL SLEEVE	2
25	26640019	BUSH, SEAL SLEEVE	2
26	26600045	M6X16 SOCKET HEAD CAP SCREW	8
	26640015	M6 SPRING WASHER BLACKODIZED (WITH SCREW)	8
27	26600050	OIL PLUG 1/2" NPT	1
28	26620002	OIL PLUG 3/8" NPT	2
29	26640013	M10X25 HEX HEAD BOLT	4
30	26640021	M8 HEX NUT	36
31	26640034	M8x30 HEX HEAD BOLT	16
32	26640033	O-RING, MANIFOLD	4
	26640024	O-RING, MANIFOLD PTFE	4

Item	Part No.	Description	QTY
33	26640021	M8 HEX NUT	30
34	26640034	M8x30 HEX HEAD BOLT	16
35	26640006	M10 EYE-BOLT	1
36	26640023	M10 LOCK WASHER, STAINLESS	12
37	26640022	M10X35 SOCKET HEAD BOLT, STAINLESS	12
38	26640014	M12X24 SOCKET HEAD CAP SCREW, STAINLESS	14
39	26640040	O-RING, STOPPER CAGE	4
40	26640032	O-RING, SEAT VALVE	8
41	88940005	CARRIAGE	1
42	88940006	YOKE	1
43	26640003	CIRCLIP INTERNAL, YOKE	1
44	88940002	ECCENTRIC CRANKSHAFT STD STROKE	1
45	88940006	YOKE PIN	2
46	26640011	BUSH, YOKE	4
47	26640010	M4X20 SET SCREW	2
48	26640009	NEEDLE BEARING	1
49	26640034	TAPPER ROLLER BEARING	2
50	26640012	VENT PLUG 1/4" BSP	2
51	26600006	M6X20 HEX HEAD BOLT BLACKODIZED	6
52	88940004	OIL SEAL CAP	1
53	26640003	CIRCLIP INTERNAL IS-3075 NI Ø80	1
54	26640001	OIL SEAL	1
55	26640004	LOCK NUT, OIL SEAL	1
56	26640005	LOCK WASHER, OIL SEAL	1
57	26600003	O-RING, OIL SEAL CAP	1
58	N/A	MOTOR EXCLUDED, REFERENCE ONLY	1
59	N/A	GEARBOX EXCLUDED, REFERENCE ONLY	1
60	26640026	JAW, COUPLING 42 (G.B DEPENDENT CONTACT CUSTOMER SERVICE)	1
61	88940025	COUPLING HOUSING Ø250 X 180	1
62	26640020	M8X40 HEX HEAD BOLT	20
63	88940008	COVER PLATE, ALUMINUM	1
64	88940009	GASKET, COVER PLATE	1
65	88940010	SIGHT GLASS, COVER PLATE	1
66	26600015	M6X16 SOCKET HEAD CAP SCREW	10
67	26640015	M6 SPRING WASHER	10
68	26600027	M6X12 SOCKET HEAD CAP SCREW	8
69	88940026	SIGHT GLASS, COUPLING HOUSING	2
70	26620014	M10x35 HEX HEAD BOLT	4

## COGNITO EODD-3", ALUMINUM PARTS

Item	Part No.	Description	QTY
1	88920058	MANIFOLD DISCHARGE, ALUMINUM (FOR NEOPRENE DIAPHRAGM)	1
	88920048	MANIFOLD DISCHARGE, ALUMINUM (FOR SANTOPRENE DIAPHRAGM)	1
2	88920025	ELBOW DISCHARGE, ALUMINUM	2
3	88920018	WET-CHAMBER, ALUMINUM (FOR NEOPRENE DIAPHRAGM)	2
	88920047	WET-CHAMBER, ALUMINUM (FOR SANTOPRENE DIAPHRAGM)	2
4	88920021	DIAPHRAGM PLATE, ALUMINUM (FOR NEOPRENE DIAPHRAGM)	2
	88920050	DIAPHRAGM PLATE, ALUMINUM (FOR SANTOPRENE DIAPHRAGM)	2
5	88920045	OVERLAY DIAPHRAGM, SANTOPRENE	2
	88920042	OVERLAY DIAPHRAGM, PTFE (WITH 88920045)	2
6	88920044	BACKUP DIAPHRAGM, SANTOPRENE	2
	88920020	DIAPHRAGM NEOPRENE, (NOT REQUIRED #5 & #7)	2
7	88920043	SOFT WASHER, PTFE	2
8	88920059	PISTON PLATE, WCB	2
9	88920055	DIAPHRAGM ROD	2
10	88920017	SEAL SLEEVE, STAINLESS STEEL	2
11	88920028	ELBOW SUCTION, ALUMINUM	2
12	88920012	PUMP BASE	1
13	88920013	GEARBOX SUPPORT 7.5HP VERTICAL (BK50)	1
	88920015	GEARBOX SUPPORT 7.5HP INLINE (AS45)	1
14	15600026	CONDUCTIVE SENSOR	2
15	88920027	MANIFOLD SUCTION, ALUMINUM (FOR NEOPRENE DIAPHRAGM)	1
	88920049	MANIFOLD SUCTION, ALUMINUM (FOR SANTOPRENE DIAPHRAGM)	1
16	88920010	BACK CHAMBER RHS	1
17	88920001	CENTRE CONSOLE	1
18	88920011	BACK CHAMBER LHS	1
19	88920029	STOPPER CAGE	4
20	88920031	CHECK BALL VALVE, NEOPRENE	4
	88920032	CHECK BALL VALVE, SANTOPRENE	4
	88920039	CHECK BALL VALVE, PTFE	4
21	88920030	CHECK VALVE SEAT, S.S	4
	88920041	CHECK VALVE SEAT, PTFE	4
22	26620006	WIPER SEAL	2
23	26620007	ROD SEAL	2
24	26620008	O-RING, SEAL SLEEVE	2
25	26620005	BUSH, SEAL SLEEVE	2
26	26600045	M6X16 SOCKET HEAD CAP SCREW	8
27	26600050	OIL PLUG 1/2" NPT	3
28	26620002	OIL PLUG 3/8" NPT	1
29	26600031	M12X24 HEX HEAD BOLT	4
30	26620018	M10 HEX NUT	36
31	26620014	M10x35 HEX HEAD BOLT	16

Item	Part No.	Description	QTY
32	26620019	O-RING, MANIFOLD	4
	88920040	O-RING, MANIFOLD PTFE	4
33	26620018	M10 HEX NUT	30
34	26620014	M10x35 HEX HEAD BOLT	16
35	26600042	M16 EYE-BOLT	1
36	26600053	M12 LOCK WASHER, STAINLESS	12
37	26600057	M12X40 HEX HEAD BOLT, STAINLESS (FOR NEOPRENE DIAPHRAGM)	12
	26600048	M12X45 HEX HEAD BOLT, STAINLESS (FOR SANTOPRENE DIAPHRAGM)	12
38	26620010	M20X30 SOCKET HEAD CAP SCREW, STAINLESS	14
39	26620021	O-RING, STOPPER CAGE	4
40	26620022	O-RING, SEAT VALVE	8
41	88920051	CARRIAGE	1
42	88920052	YOKE	1
43	26600005	CIRCLIP INTERNAL, YOKE	1
44	88920053	ECCENTRIC CRANKSHAFT STD STROKE	1
45	88920006	YOKE PIN	2
46	26620005	BUSH, YOKE	4
47	26600037	M6X20 SET SCREW	2
48	26600011	NEEDLE BEARING	1
49	26600001	TAPPER ROLLER BEARING	2
50	26600049	VENT PLUG 1/2" BSP	2
51	26600006	M6X20 HEX HEAD BOLT BLACKODIZED	6
52	88900003	OIL SEAL CAP	1
53	26600004	CIRCLIP INTERNAL IS-3075 NI Ø80	1
54	26600002	OIL SEAL	1
55	26600008	LOCK NUT, OIL SEAL	1
56	26600007	LOCK WASHER, OIL SEAL	1
57	26600003	O-RING, OIL SEAL CAP	1
58	N/A	MOTOR EXCLUDED, REFERENCE ONLY	1
59	N/A	GEARBOX EXCLUDED, REFERENCE ONLY	1
60	26600028	JAW, COUPLING 55 (G.B DEPENDENT CONTACT CUSTOMER SERVICE)	1
61	88900026	COUPLING HOUSING Ø300	1
62	26620015	M10X50 HEX HEAD BOLT (FOR NEOPRENE DIAPHRAGM)	20
	26620024	M10X60 HEX HEAD BOLT (FOR SANTOPRENE DIAPHRAGM)	20
63	88920008	COVER PLATE, ALUMINUM	1
64	26620020	GASKET, COVER PLATE	1
65	88920009	SIGHT GLASS, COVER PLATE	1
66	26620011	M8X16 SOCKET HEAD CAP SCREW	10
67	26620012	M8 SPRING WASHER	10
68	26600027	M6X12 SOCKET HEAD CAP SCREW	8
69	88900028	SIGHT GLASS, COUPLING HOUSING (FOR ITEM 61 Ø300 & Ø250)	2
70	26600025	M12X50 HEX HEAD BOLT	14

## COGNITO EODD-4", ALUMINUM PARTS

Item	Part No.	Description	QTY
1	88900061	MANIFOLD DISCHARGE, ALUMINUM (FOR NEOPRENE DIAPHRAGM)	1
	88900056	MANIFOLD DISCHARGE, ALUMINUM (FOR SANTOPRENE DIAPHRAGM)	1
2	88900020	ELBOW DISCHARGE, ALUMINUM	2
3	88900014	WET-CHAMBER, ALUMINUM (FOR NEOPRENE DIAPHRAGM)	2
	88900055	WET-CHAMBER, ALUMINUM (FOR SANTOPRENE DIAPHRAGM)	2
4	88900016	DIAPHRAGM PLATE, ALUMINUM (FOR NEOPRENE DIAPHRAGM)	2
	88900058	DIAPHRAGM PLATE, ALUMINUM (FOR SANTOPRENE DIAPHRAGM)	2
5	88900054	OVERLAY DIAPHRAGM, SANTOPRENE	2
	88900051	OVERLAY DIAPHRAGM, PTFE (WITH 88900054)	2
6	88900053	BACKUP DIAPHRAGM, SANTOPRENE	2
	88900015	DIAPHRAGM NEOPRENE, (NOT REQUIRED #5 & #7)	2
7	88900052	SOFT WASHER, PTFE	2
8	88900062	PISTON PLATE, WCB	2
9	88900018	DIAPHRAGM ROD	2
10	88900036	SEAL SLEEVE, STAINLESS STEEL	2
11	88900024	ELBOW SUCTION, ALUMINUM	2
12	88900012	PUMP BASE, HORIZONTAL (FOR HORIZONTAL MOUNT GB)	1
	88900011	PUMP BASE, VERTICAL (FOR VERTICAL MOUNT GB)	1
13	88900012-1	GEARBOX SUPPORT, HORIZONTAL (FOR HORIZONTAL MOUNT GB)	1
	88900011-1	GEARBOX SUPPORT, VERTICAL (FOR VERTICAL MOUNT GB)	1
14	15600026	CONDUCTIVE SENSOR	2
15	88900023	MANIFOLD SUCTION, ALUMINUM (FOR NEOPRENE DIAPHRAGM)	1
	88900057	MANIFOLD SUCTION, ALUMINUM (FOR SANTOPRENE DIAPHRAGM)	1
16	88900009	BACK CHAMBER RHS	1
17	88900001	CENTRE CONSOLE	1
18	88900010	BACK CHAMBER LHS	1
19	88900030	STOPPER CAGE	4
20	88900021	CHECK BALL VALVE, NEOPRENE	4
	88900041	CHECK BALL VALVE, SANTOPRENE	4
	88900048	CHECK BALL VALVE, PTFE	4
21	88900034	CHECK VALVE SEAT, S.S	4
	88900050	CHECK VALVE SEAT, PTFE	4
22	26600013	WIPER SEAL	2
23	26600014	ROD SEAL	2
24	26600016	O-RING, SEAL SLEEVE	2
25	26600012	BUSH, SEAL SLEEVE	2
26	26600045	M6X16 SOCKET HEAD CAP SCREW	8
27	26600050	OIL PLUG 1/2" NPT	2
28	26600047	OIL PLUG 3/4" NPT	2
29	26600031	M12X24 HEX HEAD BOLT	4
30	26600023	M12 HEX NUT	36
31	26600025	M12X50 HEX HEAD BOLT	16

Item	Part No.	Description	QTY
32	26600024	O-RING, MANIFOLD	4
	88900049	O-RING, MANIFOLD PTFE	4
33	26600023	M12 HEX NUT	30
34	26600025	M12X50 HEX HEAD BOLT	16
35	26600042	M16 EYE-BOLT	1
36	26600053	M12 LOCK WASHER, STAINLESS	12
37	26600057	M12X40 HEX HEAD BOLT, STAINLESS (FOR NEOPRENE DIAPHRAGM)	12
	26600048	M12X45 HEX HEAD BOLT, STAINLESS (FOR SANTOPRENE DIAPHRAGM)	12
38	26600044	M20X35 SOCKET HEAD CAP SCREW, STAINLESS	14
39	26600032	O-RING, STOPPER CAGE	4
40	26600046	O-RING, SEAT VALVE (STAINLESS SEAT)	8
41	88900004	CARRIAGE	1
42	88900006	YOKE	1
43	26600005	CIRCLIP INTERNAL, YOKE	1
44	88900002	ECCENTRIC CRANKSHAFT STD STROKE	1
45	88900005	YOKE PIN	2
46	26600012	BUSH, YOKE	4
47	26600037	M6X20 SET SCREW	2
48	26600011	NEEDLE BEARING	1
49	26600001	TAPPER ROLLER BEARING	2
50	26600049	VENT PLUG 1/2" BSP	2
51	26600006	M6X20 HEX HEAD BOLT BLACKODIZED	6
52	88900003	OIL SEAL CAP	1
53	26600004	CIRCLIP INTERNAL IS-3075 NI Ø80	1
54	26600002	OIL SEAL	1
55	26600008	LOCK NUT, OIL SEAL	1
56	26600007	LOCK WASHER, OIL SEAL	1
57	26600003	O-RING, OIL SEAL CAP	1
58	N/A	MOTOR EXCLUDED, REFERENCE ONLY	1
59	N/A	GEARBOX EXCLUDED, REFERENCE ONLY	1
60	26600029	JAW, COUPLING 75 (G.B DEPENDENT CONTACT CUSTOMER SERVICE)	1
	26600028	JAW, COUPLING 55 (G.B DEPENDENT CONTACT CUSTOMER SERVICE)	1
61	88900040	COUPLING HOUSING Ø300x266 (FOR HORIZONTAL MOUNT GEARBOX)	1
	88900027	COUPLING HOUSING Ø350 (FOR VERTICAL MOUNT GEARBOX)	1
62	26600022	M12X70 HEX HEAD BOLT (FOR NEOPRENE DIAPHRAGM)	20
	26600054	M12X80 HEX HEAD BOLT (FOR SANTOPRENE DIAPHRAGM)	20
63	88900007	COVER PLATE, ALUMINUM	1
64	26600026	GASKET, COVER PLATE	1
65	88900008	SIGHT GLASS, COVER PLATE	1
66	26600018	M10X20 SOCKET HEAD CAP SCREW	10
67	26600019	M10 SPRING WASHER	10
68	26600027	M6X12 SOCKET HEAD CAP SCREW	8
69	88900035	SIGHT GLASS, COUPLING HOUSING (FOR ITEM 61 Ø350 & Ø300x266)	2
70	26600025	M12X50 HEX HEAD BOLT	14

### 5.3 Cognito EODD SS Pump

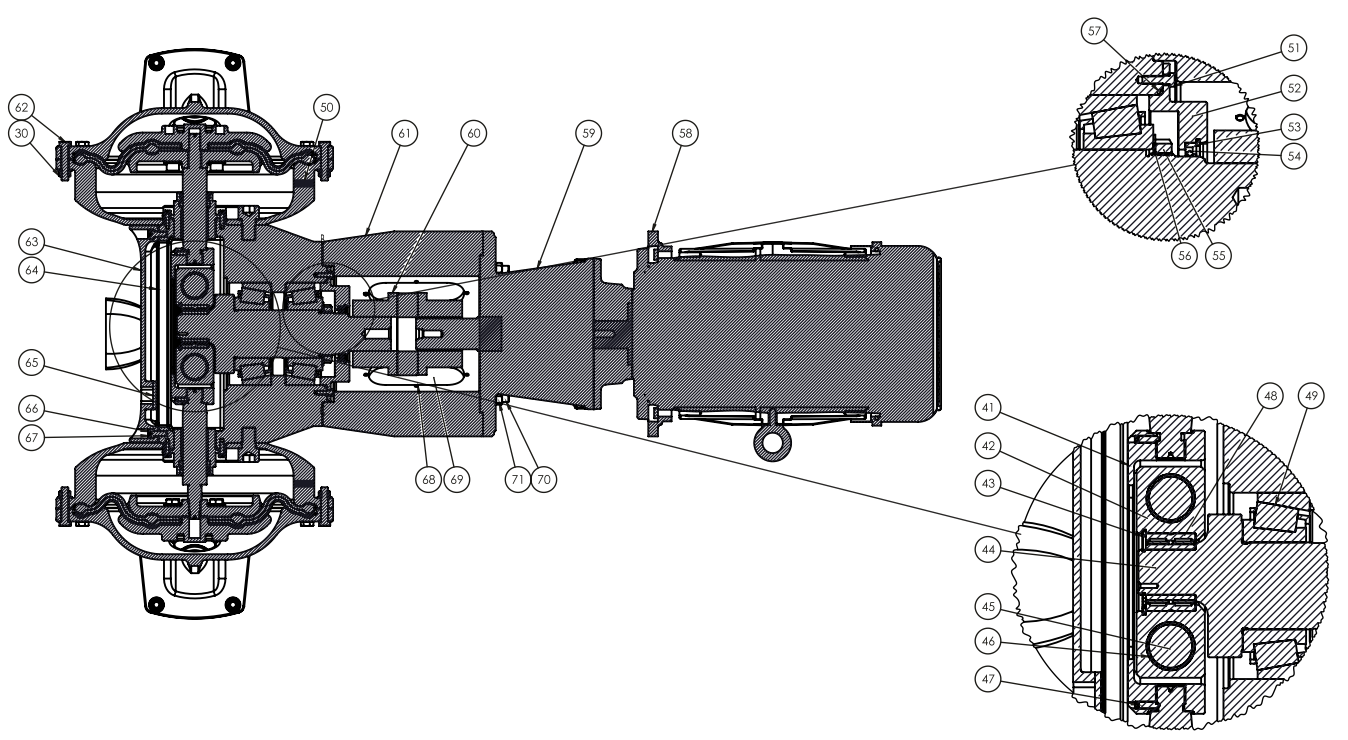
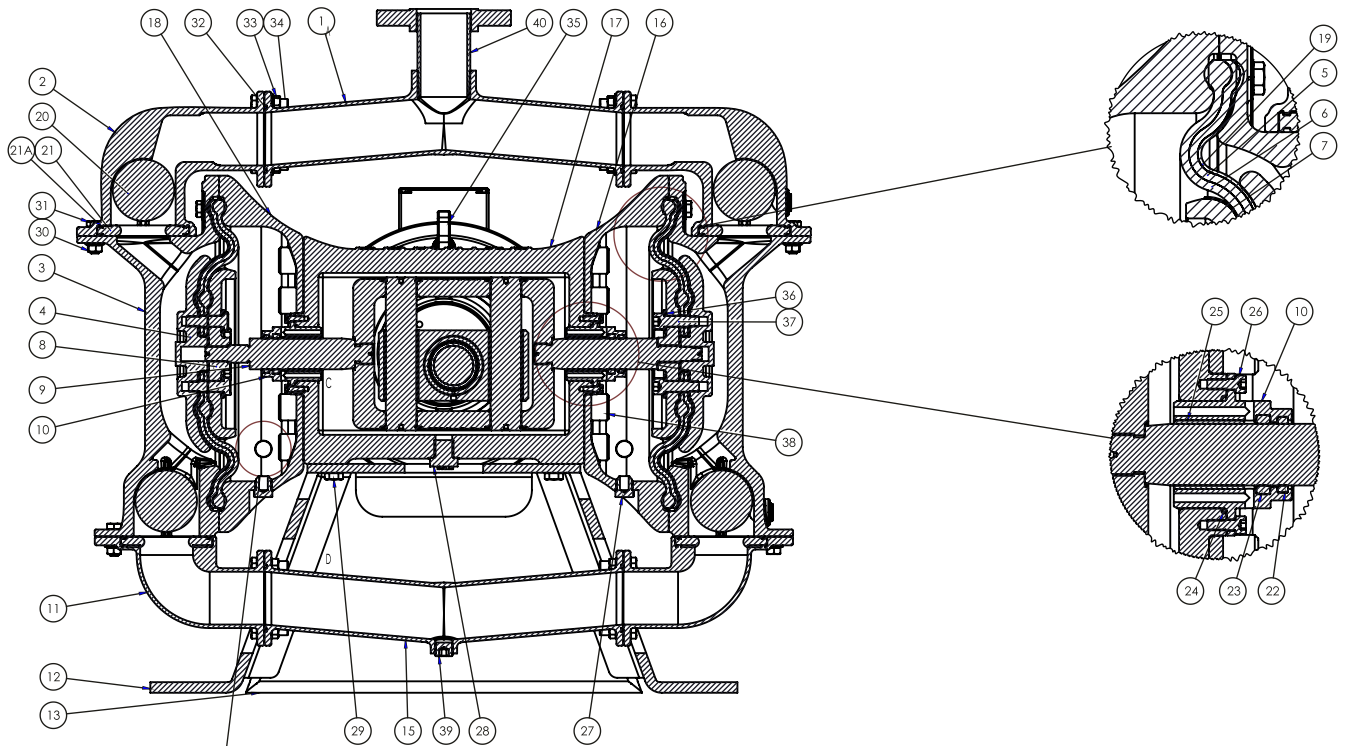

## COGNITO EODD-2", STAINLESS STEEL PARTS

Item	Part No	Description	QTY
1	88940031	MANIFOLD DISCHARGE, STAINLESS	1
2	88940032	ELBOW DISCHARGE, STAINLESS	2
3	88940028	WET-CHAMBER, STAINLESS	2
4	88940029	DIAPHRAGM PLATE, STAINLESS	2
5	88940044	OVERLAY DIAPHRAGM, SANTOPRENE	2
6	88940045	BACKUP DIAPHRAGM, SANTOPRENE	2
7	88940040	SOFT WASHER, PTFE	2
8	88940030	PISTON PLATE, STAINLESS	2
9	88940019	DIAPHRAGM ROD	2
10	88940015	SEAL SLEEVE, STAINLESS STEEL	2
11	88940034	SEAL SLEEVE, STAINLESS STEEL	2
12	88940013	ELBOW SUCTION, STAINLESS	2
13	88940014	GEARBOX SUPPORT 5HP INLINE (AS35)	1
	88940035	GEARBOX SUPPORT 5HP VERTICAL (BK 40)	1
14	26640028	CONDUCTIVE SENSOR	2
15	88940033	MANIFOLD SUCTION, STAINLESS	1
16	88940011	BACK CHAMBER RHS	1
17	88940001	CENTRE CONSOLE	1
18	88940012	BACK CHAMBER LHS	1
19	88940039	OVERLAY DIAPHRAGM, PTFE	2
20	88940041	CHECK BALL VALVE, SANTOPRENE (WITH SANTOPRENE DIAPHRAGM)	4
	88940042	CHECK BALL VALVE, PTFE	4
21	88940022	CHECK VALVE SEAT, METALLIC (WITH SANTOPRENE DIAPHRAGM)	4
	88940043	CHECK VALVE SEAT, PTFE	4
21A	26640032	O-RING, SEAT VALVE (WITH PART NO #88940022)	8
22	26640016	WIPER SEAL	2
23	26640017	ROD SEAL	2
24	26640018	O-RING, SEAL SLEEVE	2
25	26640019	BUSH, SEAL SLEEVE	2
26	26600045	M6X16 SOCKET HEAD CAP SCREW	8
	26640015	M6 SPRING WASHER BLACKODIZED (WITH SCREW)	8
27	26600050	OIL PLUG 1/2" NPT	1
28	26620002	OIL PLUG 3/8" NPT	2
29	26640013	M10X25 HEX HEAD BOLT	4
30	26640043	M8 HEX NUT HOT-DEEP GLV	36
31	26640042	M8X30 HEX BOLT HOT-DEEP GLV	16
32	26640033	O-RING, MANIFOLD (WITH SANTOPRENE DIAPHRAGM)	4
	26640024	O-RING, MANIFOLD, PTFE	4

Item	Part No	Description	QTY
33	26640043	M8 HEX NUT HOT-DEEP GLV	30
34	26640042	M8X30 HEX BOLT HOT-DEEP GLV	16
35	26640006	M10 EYE-BOLT	1
36	26640023	M10 LOCK WASHER, STAINLESS	12
37	26640031	M10X40 HEX HEAD BOLT, STAINLESS	12
38	26640014	M12X24 SOCKET HEAD CAP SCREW, STAINLESS	14
39	26620002	DRAIN PLUG, 3/8" NPT (OPTIONAL)	5
40	88930017	2" FLANGES SPOOL, STAINLESS	1
41	88940005	CARRIAGE	1
42	88940006	YOKE	1
43	26640003	CIRCLIP INTERNAL, YOKE	1
44	88940002	ECCENTRIC CRANKSHAFT STD STROKE	1
45	88940006	YOKE PIN	2
46	26640011	BUSH, YOKE	4
47	26640010	M4X20 SET SCREW	2
48	26640009	NEEDLE BEARING	1
49	26640034	TAPPER ROLLER BEARING	2
50	26640012	VENT PLUG 1/4" BSP	2
51	26600006	M6X20 HEX HEAD BOLT BLACKODIZED	6
52	88940004	OIL SEAL CAP	1
53	26640003	CIRCLIP INTERNAL IS-3075 NI Ø80	1
54	26640001	OIL SEAL NBR 50 X 72 X 8MM	1
55	26640004	LOCK NUT, OIL SEAL	1
56	26640005	LOCK WASHER, OIL SEAL	1
57	26600003	O-RING, OIL SEAL CAP	1
58	N/A	MOTOR EXCLUDED, REFERENCE ONLY	1
59	N/A	GEARBOX EXCLUDED, REFERENCE ONLY	1
60	26640026	JAW, COUPLING 42 (G.B DEPENDENT CONTACT CUSTOMER SERVICE)	1
61	88940025	COUPLING HOUSING Ø250 X 180	1
62	26640041	M8X40 HEX BOLT HOT-DEEP GLV	20
63	88940008	COVER PLATE, ALUMINUM	1
64	88940009	GASKET, COVER PLATE	1
65	88940010	SIGHT GLASS, COVER PLATE	1
66	26600015	M6X16 SOCKET HEAD CAP SCREW	10
67	26640015	M6 SPRING WASHER	10
68	26600027	M6X12 SOCKET HEAD CAP SCREW	8
69	88940026	SIGHT GLASS, COUPLING HOUSING	2
70	26620014	M10x35 HEX HEAD BOLT	4



## COGNITO EODD-3", STAINLESS STEEL PARTS

Item	Part No	Description	QTY
1	88920034	MANIFOLD DISCHARGE, STAINLESS	1
2	88920035	ELBOW DISCHARGE, STAINLESS	2
3	88920033	WET-CHAMBER, STAINLESS	2
4	88920037	DIAPHRAGM PLATE, STAINLESS	2
5	88920045	OVERLAY DIAPHRAGM, SANTOPRENE	2
6	88920044	BACKUP DIAPHRAGM, SANTOPRENE	2
7	88920043	SOFT WASHER, PTFE	2
8	88920038	PISTON PLATE, STAINLESS	2
9	88920055	DIAPHRAGM ROD	2
10	88920017	SEAL SLEEVE, STAINLESS STEEL	2
11	88920036	ELBOW SUCTION, STAINLESS	2
12	88920012	PUMP BASE	1
13	88920013	GEARBOX SUPPORT 7.5HP VERTICAL (BK50)	1
	88920015	GEARBOX SUPPORT 7.5HP INLINE (AS45)	1
14	15600026	CONDUCTIVE SENSOR	2
15	88920056	MANIFOLD SUCTION, STAINLESS	1
16	88920010	BACK CHAMBER RHS	1
17	88920001	CENTRE CONSOLE	1
18	88920011	BACK CHAMBER LHS	1
19	88920042	OVERLAY DIAPHRAGM, PTFE	2
20	88920039	CHECK BALL VALVE, PTFE	4
	88920032	CHECK BALL VALVE, SANTOPRENE (WITH SANTOPRENE DIAPHRAGM)	4
21	88920030	CHECK VALVE SEAT, METALLIC (WITH SANTOPRENE DIAPHRAGM)	4
21A	88920039	CHECK VALVE SEAT, PTFE	4
21B	26620022	O-RING, SEAT VALVE (WITH PART NO #88920030)	8
22	26620007	WIPER SEAL	2
23	26620007	ROD SEAL	2
24	26620008	O-RING, SEAL SLEEVE	2
25	26620005	BUSH, SEAL SLEEVE	2
26	26600045	M6X16 SOCKET HEAD CAP SCREW	8
27	26600050	OIL PLUG 1/2" NPT	3
28	26620002	OIL PLUG 3/8" NPT	1
29	26600031	M12X24 HEX HEAD BOLT	4
30	26620028	M10 HEX NUT, HOT DEEP	36
31	26620027	M10x30 HEX HEAD BOLT, HOT DEEP	16
32	88920040	O-RING, MANIFOLD, PTFE	4
	26620019	O-RING, MANIFOLD (WITH SANTOPRENE DIAPHRAGM)	4

Item	Part No	Description	QTY
33	26620028	M10 HEX NUT, HOT DEEP	30
34	26620027	M10x30 HEX HEAD BOLT, HOT DEEP	16
35	26600042	M16 EYE-BOLT	1
36	26600053	M12 LOCK WASHER, STAINLESS	12
37	26600048	M12X50 HEX HEAD BOLT, STAINLESS	12
38	26620010	M20X30 SOCKET HEAD CAP SCREW, STAINLESS	14
39	26600050	DRAIN PLUG, 1/2" NPT (OPTIONAL)	5
40	88930017	2" FLANGES SPOOL, STAINLESS	1
41	88920051	CARRIAGE	1
42	88920052	YOKE	1
43	26600005	CIRCLIP INTERNAL, YOKE	1
44	88920053	ECCENTRIC CRANKSHAFT STD STROKE	1
45	88920006	YOKE PIN	2
46	26620005	BUSH, YOKE	4
47	26600037	M6X20 SET SCREW	2
48	26600011	NEEDLE BEARING	1
49	26600001	TAPPER ROLLER BEARING	2
50	26600049	VENT PLUG 1/2" BSP	2
51	26600006	M6X20 HEX HEAD BOLT BLACKODIZED	6
52	88900003	OIL SEAL CAP	1
53	26600004	CIRCLIP INTERNAL IS-3075 NI Ø80	1
54	26600002	OIL SEAL NBR 60 X 80 X 8MM	1
55	26600008	LOCK NUT, OIL SEAL	1
56	26600007	LOCK WASHER, OIL SEAL	1
57	26600003	O-RING, OIL SEAL CAP	1
58	N/A	MOTOR EXCLUDED, REFERENCE ONLY	1
59	N/A	GEARBOX EXCLUDED, REFERENCE ONLY	1
60	26600028	JAW, COUPLING 55 (G.B DEPENDENT CONTACT CUSTOMER SERVICE)	1
61	88900026	COUPLING HOUSING Ø300	1
62	26620026	M10X55 HEX BOLT HOT-DEEP GLV	20
63	88920008	COVER PLATE, ALUMINUM	1
64	26620020	GASKET, COVER PLATE	1
65	88920009	SIGHT GLASS, COVER PLATE	1
66	26620011	M8X16 SOCKET HEAD CAP SCREW	10
67	26620012	M8 SPRING WASHER	10
68	26600027	M6X12 SOCKET HEAD CAP SCREW	8
69	88900028	SIGHT GLASS, COUPLING HOUSING (FOR ITEM 61 Ø300 & Ø250)	2
70	26600025	M12X50 HEX HEAD BOLT	14

## COGNITO EODD-4", STAINLESS STEEL PARTS

Item	Part No	Description	QTY
1	88900043	MANIFOLD DISCHARGE, STAINLESS	1
2	88900044	ELBOW DISCHARGE, STAINLESS	2
3	88900042	WET-CHAMBER, STAINLESS	2
4	88900046	DIAPHRAGM PLATE, STAINLESS	2
5	88900054	OVERLAY DIAPHRAGM, SANTOPRENE	2
6	88900053	BACKUP DIAPHRAGM, SANTOPRENE	2
7	88900052	SOFT WASHER, PTFE	2
8	88900047	PISTON PLATE, STAINLESS	2
9	88900018	DIAPHRAGM ROD	2
10	88900036	SEAL SLEEVE, STAINLESS STEEL	2
11	88900045	ELBOW SUCTION, STAINLESS	2
12	88900012	PUMP BASE, HORIZONTAL (FOR HORIZONTAL MOUNT GB)	1
	88900011	PUMP BASE, VERTICAL (FOR VERTICAL MOUNT GB)	1
13	88900012-1	GEARBOX SUPPORT, HORIZONTAL (FOR HORIZONTAL MOUNT GB)	1
	88900011-1	GEARBOX SUPPORT, VERTICAL (FOR VERTICAL MOUNT GB)	1
14	15600026	CONDUCTIVE SENSOR	2
15	88900059	MANIFOLD SUCTION, STAINLESS	1
16	88900009	BACK CHAMBER RHS	1
17	88900001	CENTRE CONSOLE	1
18	88900010	BACK CHAMBER LHS	1
19	88900051	OVERLAY DIAPHRAGM, PTFE	2
20	88900048	CHECK BALL VALVE, PTFE	4
	88900041	CHECK BALL VALVE, SANTOPRENE (WITH SANTOPRENE DIAPHRAGM)	4
21	88900034	CHECK VALVE SEAT, METALLIC (WITH SANTOPRENE DIAPHRAGM)	4
	88900050	CHECK VALVE SEAT, PTFE	4
21A	26600046	O-RING, SEAT VALVE (WITH PART NO #88900034)	8
22	26600013	WIPER SEAL	2
23	26600014	ROD SEAL	2
24	26600016	O-RING, SEAL SLEEVE	2
25	26600012	BUSH, SEAL SLEEVE	2
26	26600045	M6X16 SOCKET HEAD CAP SCREW	8
27	26600050	OIL PLUG 1/2" NPT	2
28	26600047	OIL PLUG 3/4" NPT	2
29	26600031	M12X24 HEX HEAD BOLT	4
30	26600059	M12 HEX NUT, HOT-DEEP GLV	36
31	26600060	M12X45 HEX HEAD BOLT, HOT-DEEP GLV	16
32	88900049	O-RING, MANIFOLD, PTFE	4
	26600024	"O-RING, MANIFOLD (WITH SANTOPRENE DIAPHRAGM)"	4
33	26600059	M12 HEX NUT, HOT-DEEP GLV	30

Item	Part No	Description	QTY
34	26600060	M12X45 HEX HEAD BOLT, HOT-DEEP GLV	16
35	26600042	M16 EYE-BOLT	1
36	26600053	M12 LOCK WASHER, STAINLESS	12
37	26600048	M12X50 HEX HEAD BOLT, STAINLESS	12
38	26600044	M20X35 SOCKET HEAD CAP SCREW, STAINLESS	14
39	26600050	DRAIN PLUG, 1/2" NPT (OPTIONAL)	5
40	88910023	3" FLANGES SPOOL, STAINLESS	1
41	88900004	CARRIAGE	1
42	88900006	YOKE	1
43	26600005	CIRCLIP INTERNAL, YOKE	1
44	88900002	ECCENTRIC CRANKSHAFT STD STROKE	1
45	88900005	YOKE PIN	2
46	26600012	BUSH, YOKE	4
47	26600037	M6X20 SET SCREW	2
48	26600011	NEEDLE BEARING	1
49	26600001	TAPPER ROLLER BEARING	2
50	26600049	VENT PLUG 1/2" BSP	2
51	26600006	M6X20 HEX HEAD BOLT BLACKODIZED	6
52	88900003	OIL SEAL CAP	1
53	26600004	CIRCLIP INTERNAL IS-3075 NI Ø80	1
54	26600002	SHAFT SEAL	1
55	26600008	LOCK NUT, OIL SEAL	1
56	26600007	LOCK WASHER, OIL SEAL	1
57	26600003	O-RING, OIL SEAL CAP	1
58	N/A	MOTOR EXCLUDED, REFERENCE ONLY	1
59	N/A	GEARBOX EXCLUDED, REFERENCE ONLY	1
60	26600029	JAW, COUPLING 75 (G.B DEPENDENT CONTACT CUSTOMER SERVICE)	1
	26600028	JAW, COUPLING 55 (G.B DEPENDENT CONTACT CUSTOMER SERVICE)	1
61	88900040	COUPLING HOUSING Ø300x266 (FOR HORIZONTAL MOUNT GEARBOX)	1
	88900027	COUPLING HOUSING Ø350 (FOR VERTICAL MOUNT GEARBOX)	1
62	26600058	M12X70 HEX BOLT HOT-DEEP GLV	20
63	88900007	COVER PLATE, ALUMINUM	1
64	26600026	GASKET, COVER PLATE	1
65	88900008	SIGHT GLASS, COVER PLATE	1
66	26600018	M10X20 SOCKET HEAD CAP SCREW	10
67	26600019	M10 SPRING WASHER	10
68	26600027	M6X12 SOCKET HEAD CAP SCREW	8
69	88900035	SIGHT GLASS, COUPLING HOUSING (FOR ITEM 61 Ø350 & Ø300x266)	2
70	26600025	M12X50 HEX HEAD BOLT	14

## 5.4 Diaphragm Assembly Exploded View

(a) SANTOPRENE Diaphragm Assembly

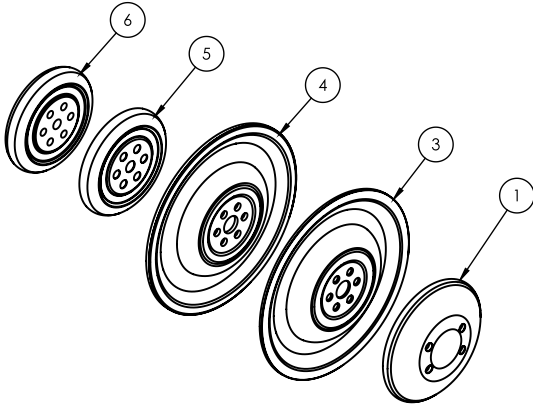

(b) SANTOPRENE + PTFE Diaphragm Assembly

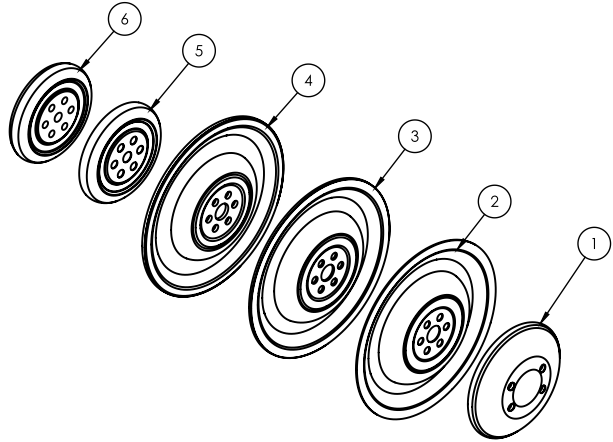

(c) NEOPRENE Diaphragm Assembly

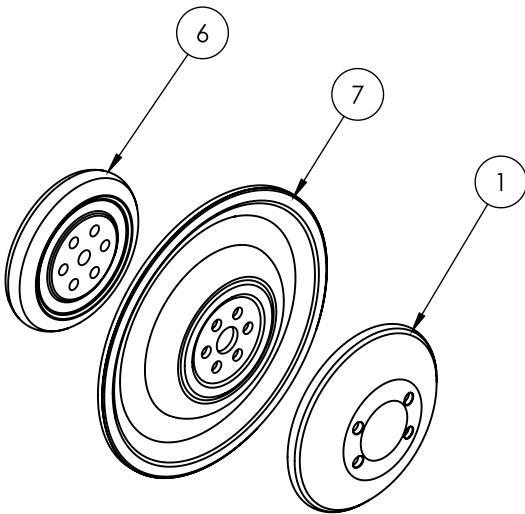

Label No	Item
1	Diaphragm Plate
2	PTFE Overlay Diaphragm
3	Santoprene Overlay Diaphragm
4	Santoprene Backup Diaphragm
5	PTFE Soft Washer
6	Piston Plate
7	Neoprene Diaphragm

Color Code	
Material	Diaphragm Color
Neoprene	Black
Santoprene	Red
PTFE	White

The variable frequency drive is recommend but it is permissible to use a soft starter instead with the proper gearbox reduction ratio selected for the desired output speed. The VFD will need separately sourced by the end user as this is currently not available with the pump. If equipped, it is recommended to use the Over Torque Detection Level setting at slightly above the rated pump pressure. Other settings may need adjusted to run the pump. The two leak sensors can either be wired into the VFD or PLC to trip a fault.

The below configuration chart are recommended settings to use in the Delta brand VFD model MS300. Parameter code and descriptions may very so it is recommend to consult the VFD manufacturer.

Parameter	Parameter Description	Set Value	Operation
00-02	Parameter Reset	9	Reset All Parameter to 50Hz
00-20	Frequency Command	2	External Analog Reference
00-21	Operation Command	1	External Terminals
01-12	Acceleration Time	120	Modified Setting (120)
01-13	De-acceleration Time	10	Modified Setting (10)
02-00	Operation Control	2	M1-Run & MI3-Stop (Modified Setting-1)
02-04	Multifunction IP (MI4) Command	18	Force to Stop
02-05	Multifunction IP (MI5) Command	40	Force to Stop
02-12	Multifunction IP Selection	0	24 For NC Contact Mi4 & 5 (Modified Setting-0)
02-13	Multifunction OP 1	1	Indication During Run
02-35	External Operation Control Selection After Reset & Reboot	1	Drive Run If the Run Command Remain After Reset or Reboot
06-06	Over Torque Detection Selection	4	Stop After Over Torque Detection
06-07	Over Torque Detection Level	90	For 6 Bar=90%
06-08	Over Torque Detection Time	0.1	0.1 - 60.0 Secs
07-20	Emergency Stop Selection	5	System Deceleration
09-00	Communication Address	1	Device Address
09-01	Comn. Transmission Speed	9.6	9600 kbps
09-04	Comn. Protocol	12	8, N, 1 RTU

**7.1 Leak Detection Sensor Assembly: Safe Area Application (Non-hazardous Location)**

1. There are 2 leak detectors (one for left diaphragm and another for right diaphragm) which come with 5 meters (16.4 ft) of cable. The 2 wire leads are color coded: red is positive and black is negative.
2. The leak detection sensors require 24V power and should be connected to the digital input terminals of the PLC or VFD. The PLC or VFD can be programmed so that the digital signal will trigger the pump to ramp down to a stop or send an alert of a leak for example. The sensor is normally open (NO) until the leaked fluid creates continuity.
3. When the process fluid, which the pump was pumping, leaks onto the sensor via a diaphragm failure, it completes the electrical circuit. If the process fluid is non-conductive, a different sensor will need incorporated such as a float switch.

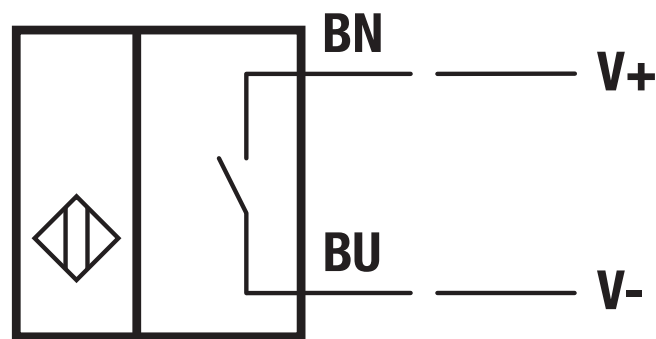

## 7.2 Leak Detection Sensor Assembly: Hazardous Area Application (ATEX / IECEx)

1. There are 2 leak detection sensors that are used per pump which come with hermetically Sealed specified cable length.
2. Both Leak detection sensors need to connect with Hazardous area specified Terminal box
3. Terminal box connected with Barrier Switch Amplifier which is fitted in VFD Panel which is Placed in Safe Area through Armour cable.
4. All connections Should be wired as shown by the schematic below by a qualified and certified electrician according to any local and national electric codes.

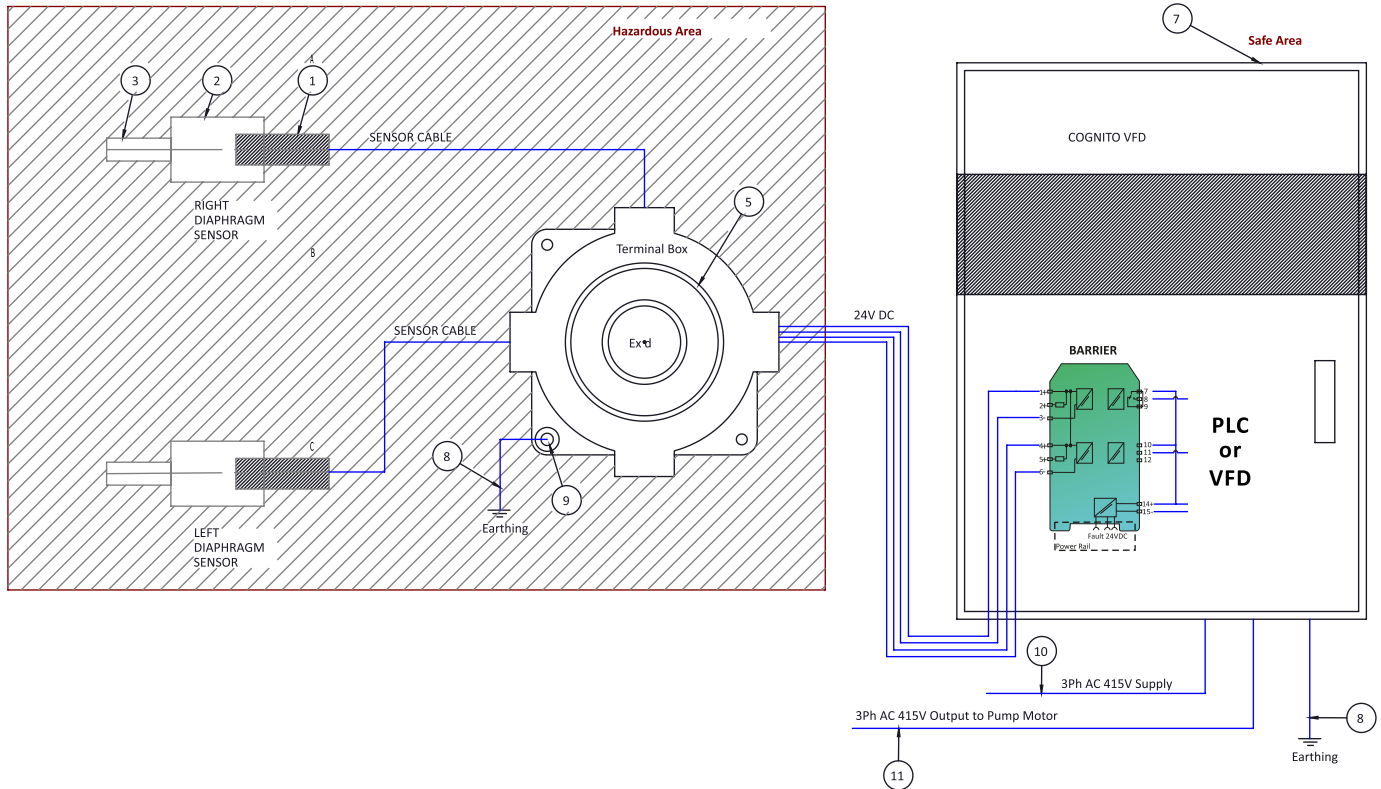

BOM			
Baloon No.	Description	Size & MOC	Qty.
1	Capacitive Sensor ATEX CJ4-12GK-N	M12X1	2
2	Delrin Adaptor	1/2" BSP TO M12X1	2
3	Pipe Nipple Male	1/2" BSP, M.S	2
4	24V DC Cable	Actual	-
5	Ex D Terminal Box, 8252/13-0DDDD-111	8252/13-0DDDD-111*	1-KIT
6	Barrier Switch Amplifier	EXCLUDED, REFERENCE ONLY	
7	Control Panel		
8	Earthing Cable, with Lug		
9	Cable Lug		
10	Ex Armed Cable Supply		
11	Ex Armed Cable Output		

\*Not certified for HazLoc (Class-Division/Zone)

8.1 Pump Components

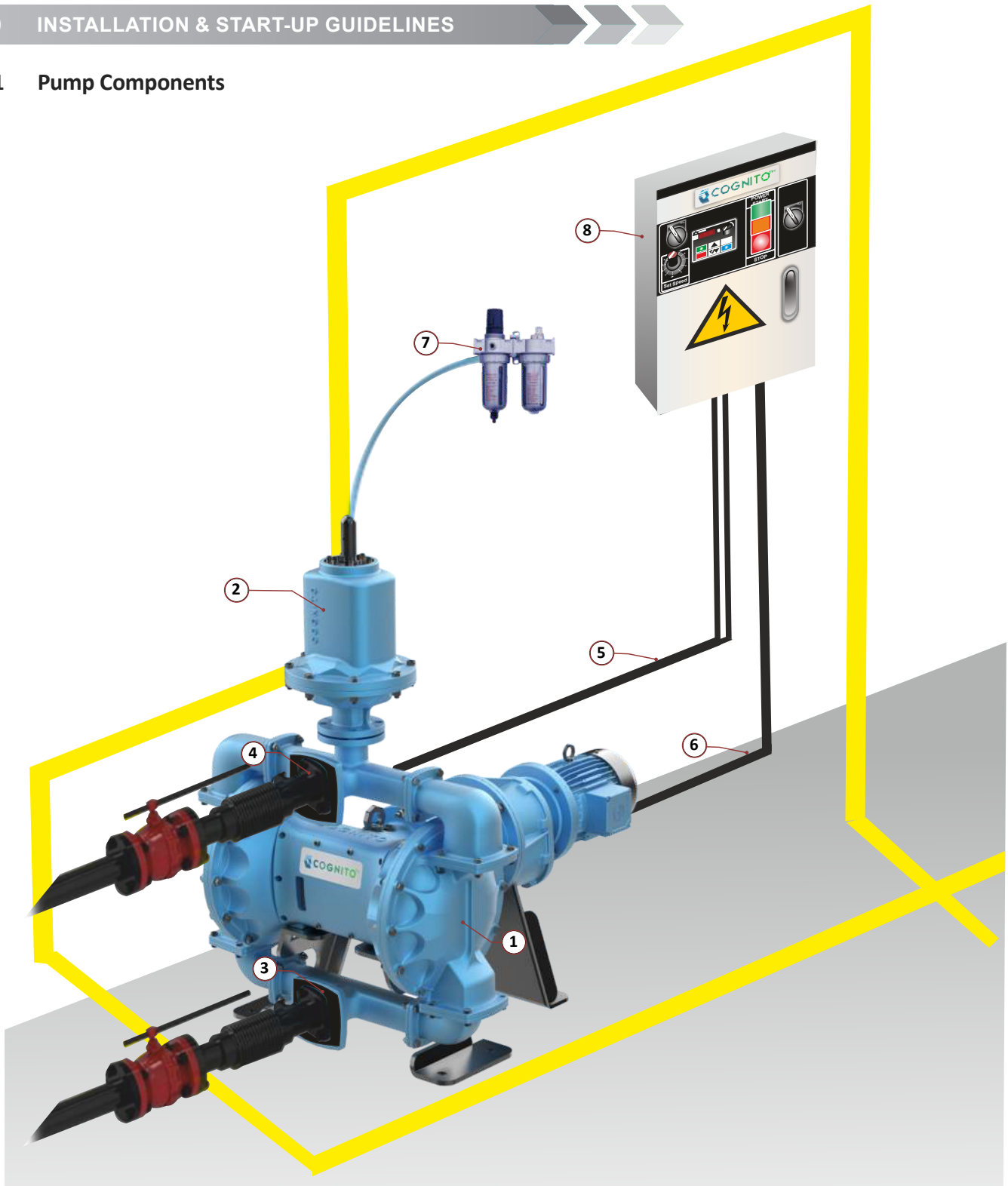

Serial	Details	Serial	Details
1	Pump	5	Leak Detection Sensor Cable(optional)
2	Dampener (optional)	6	Motor Wire (reference only)
3	Suction Flange	7	Filter and Regulator (reference only)
4	Discharge Flange	8	Control Panel (reference only)

## 8.2 Installation Guidelines

1. Locate the pump as close as to the product being pumped if possible.
2. Make sure to have leveled foundation floor.
3. Drill the holes for Anchor fasteners.
4. Clean & install the anchor fastener bolts on the previously drilled holes.
5. Position the pump and align the holes on pump to the holes made on the floor.
6. Fasten the anchor fastener nuts and secure the pump.
7. Connect the suction port (Inlet) & discharge port (Outlet) with the expansion rubber bellows.
8. Fix the Control Panel on the wall as per Control Panel installation guideline (Not Included).
9. Avoid any tight bends or drastic reduction in the pipeline.
10. Connect the sensor wires from the pump to the corresponding port on the VFD or PLC.
11. Connect the motor wire to the Control Panel.
12. Connect Pneumatic Air Supply to Filter & Regulator unit of Dampener.
13. Connect the main Power Supply to the Control Panel. Do not start pump, yet! Go through the Pre-start Procedure and check list mentioned in the manual, before starting the pump.
14. Inspect for any sign of leakages, If found, tighten the fittings and fasteners as per the recommended torque. If leakage still persists, contact customer service. Torque details are mentioned after startup procedure.
15. It is recommended to install a pressure gauge and pressure relief valve.

## 8.3 Prerequisite Before Starting Pump Operation

1. Ensure 3-phase Power Supply provided to the Control Panel is from reliable source and it matches voltage and frequency of VFD drive and motor.
2. All cables inside the Control Panel should be connected with proper lugging. Ensure all cables are gently fastened and cable glands are firmly tightened.
3. Ensure all foundation bolts are firmly tightened.
4. Ensure Panel is fixed properly using support and verify connections as per wiring diagram before starting the pump.
5. Ensure proper grounding of the motor.
6. Check & ensure if the speed control knob is in the minimum position.
7. Rotary switch in Control Panel is available to RUN the pump either in AUTO / MANUAL mode. If switch is in the MANUAL mode, manual START is required to start the Pump.
8. Ensure pump suction valve and discharge valve is fully open before starting the pump and required air is lined up to the dampener.



## 8.4 Torque Details for Metallic Pump

COGNITO EODD-2"		
Respective Part Bolts	Size	Torque
Back-chamber Bolt	M12	40 Nm / 354 in-lb
Diaphragm Rod With Carriage	M20	hand tightened
Santoprene Diaphragm Assembly	M10	30 Nm / 266 in-lb
Santoprene+PTFE Diaphragm Assembly	M10	30 Nm / 266 in-lb
Diaphragm Assly. With Diaphragm Rod	M16	hand tightened
Wet-chamber Outer Bolts	M8	30 Nm / 266 in-lb
Manifold & Elbow Outer Bolts	M8	30 Nm / 266 in-lb

COGNITO EODD-3"		
Respective Part Bolts	Size	Torque
Back-chamber Bolt	M20	50 Nm / 443 in-lb
Diaphragm Rod With Carriage	M24	hand tightened
Neoprene Diaphragm Assembly	M12	40 Nm / 354 in-lb
Santoprene Diaphragm Assembly	M12	40 Nm / 354 in-lb
Santoprene+PTFE Diaphragm Assembly	M12	40 Nm / 354 in-lb
Diaphragm Assly. With Diaphragm Rod	M20	hand tightened
Wet-chamber Outer Bolts	M10	40 Nm / 354 in-lb
Manifold & Elbow Outer Bolts	M10	40 Nm / 354 in-lb

COGNITO EODD-4"		
Respective Part Bolts	Size	Torque
Back-chamber Bolt	M20	50 Nm / 443 in-lb
Diaphragm Rod With Carriage	M30	hand tightened
Neoprene Diaphragm Assembly	M12	40 Nm / 354 in-lb
Santoprene Diaphragm Assembly	M12	50 Nm / 443 in-lb
Santoprene+PTFE Diaphragm Assembly	M12	50 Nm / 443 in-lb
Diaphragm Assly. With Diaphragm Rod	M24	hand tightened
Wet-chamber Outer Bolts	M12	50 Nm / 443 in-lb
Manifold & Elbow Outer Bolts	M12	50 Nm / 443 in-lb

## 8.5 Grounding & Pump Earthing

### 8.5.1 Pump Earthing

1. All pumps have a ground screw installed in pump support bracket.
2. Protective paint is applied to prevent rust
3. Size of grounding screw is M8
4. Connect one end of the grounding wire to ground screw and other end of the grounding wire to suitable earth ground.
5. Keep grounding wire connection distance as short as possible
6. The cross section of grounding wire must be at least sized according to local, state, and federal requirements.
7. Make sure earthing cable connection should be properly tightened with cable lug
8. Check the local electrical code for detailed grounding instruction & the type of equipment required.

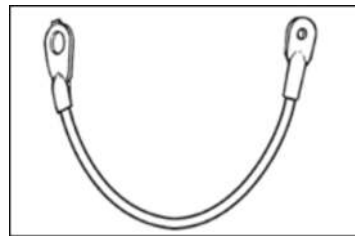
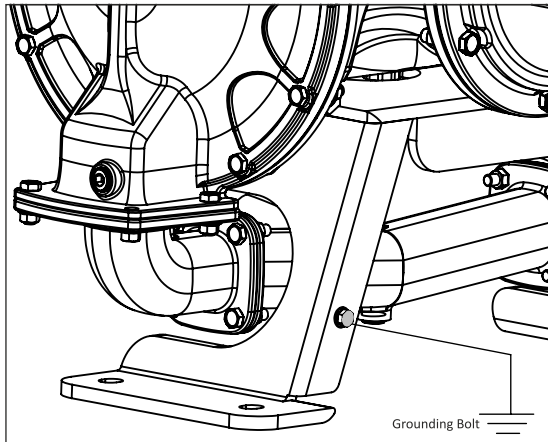

### 8.5.2 Motor Grounding

#### WARNING

1. It is compulsory to earth the motor. Earthing must be performed in accordance with current regulations (protection of workers).
2. Motors have a ground screw inside the terminal box. Use it to ground the motor
3. The cross section of grounding wire must be at least sized according to local, state, and federal requirements.

Trouble	Possible Cause	Remedy
<b>Pump not starting</b>	No power	Check & Correct Input power in all phases
	Disconnected wires	Check the wiring as per wiring schematic
	Diaphragm rupture	Check for error light of diaphragm failure, replace diaphragm
	Motor failure	Check the display for error code
<b>Low flow</b>	Incorrect rpm	Check and correct the rpm
	Incorrect opening of suction & discharge valve	Check & open valve as per our recommended opening
	Pump jammed with media	Clean & flush all pumping media path
	Stuck ball valves	Clean & flush valve
	Improper input power	Check for input power as per specs ( Hz & voltage )
	Abnormal slurry or very high viscosity	Check viscosity
<b>High flow</b>	Incorrect rpm	Check and correct the rpm
	Improper input power	Check for input power as per specs ( Hz & voltage )
	Low viscosity of pumping media	Check viscosity
<b>No flow</b>	No power	Check power supply in all phase & correct it
	Valve closed	Check the valves
	No pumping media in sump	Check & fill sump
	Stuck ball valves	Clean & flush valve
	Diaphragm rupture	Check for error light of diaphragm failure, replace
	Broken spider coupling	Check and replace spider coupling
	Motor failure	Check the display for error code
	Pump jammed with media	Clean & flush all pumping media path
<b>Tripping</b>	Incorrect line voltage	Check and correct line voltage
	Diaphragm rupture	Check for error light of diaphragm failure, replace
	Overheating of motor	Check rated duty of motor cycle
		Check cooling fan damage
		Check incorrect line voltage
Check stuck gearbox		
<b>Noise</b>	Inadequate Air pressure	Check for dampener setting
	Loose bolts	Check for loose bolt and tighten them
	Coupling wear	Check for spider wear
	Incorrect line voltage	Check for line voltage
<b>Panel not starting</b>	No power	Check power supply in all phase & correct it
	Disconnected wires	Check the wiring as per wiring schematic

Sr. no	Maintenance Item	Frequency	Indication
1	Diaphragms	As needed	Pump will be shut down by the VFD due to fluid detection by leak detection sensors installed in each of the Diaphragm.
2	Balls	As needed	Behavior, excessive pulsation, reduction in flow; visual inspection
3	Seats	As needed	Visual inspection
4	Oil change - Pump mechanism	3 months	Scheduled / visual inspection monitor oil level through sight glass fitted in pump
5	Oil change - Gear Box	Per manufacturer's recommendation	Scheduled / visual inspection per manufacturer's recommendation
6	Rod seals & Wiper seals	Once in 2 years / As needed	Scheduled / leakage / any failure
7	Rotary shaft seals	Once in 3 years / As needed	Scheduled / leakage from coupling housing
8	Bolt torque checks of outer chambers	3 months / As needed	Scheduled / visual inspection

COGNITO EODD Pumps are factory filled with long-life Synthetic lubricant, ISO VG 320 Synthetic. There is need for periodical lubricant change according to loading condition.

COGNITO PUMP LUBRICATION CHANGE FREQUENCY		
Loading Details	*Running Hours	Discoloration Code
High Load & High Speed Pressure : =>4.5bar, RPM => 80RPM	1000	
Medium Load & Medium Speed Pressure: 3-4bar, RPM: 60 - 80 RPM	2500	
Low Load & Low to Med Speed Pressure : <3bar, RPM : 50 - 80	3500	

\* Lubrication change frequency depending on loading condition, which ever comes earlier either number of hours or lubricant is turning blackish color spectrum after 6.0 according to ASTM D1500 COLOR SCALE

### Oil Replacement Procedure:

1. Unscrew the top Oil fill plug to avoid vacuuming during drain
2. Now open the cover plate and clean it thoroughly
3. Assemble the cover plate applying the grease on the gasket area
4. Close the drain plug and refill the oil with recommended oil grade & quantity
5. Do not mix different grades of oil
6. Do not exceed the recommended maximum level

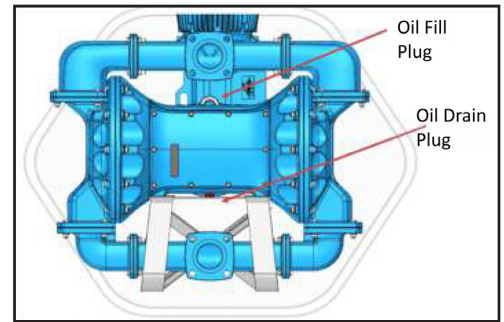

### Recommended Oil Level & Oil Grade:

COGNITO Pump Size (Metallic & Non Metallic)	Oil Qty. (Ltr.)	Oil Grade
4" Metallic & 3" Non Metallic	2.6	ISO-VG 320 Synthetic
3" Metallic & 2" Non Metallic	1.8	
2" Metallic & 1.5" Non Metallic	1.3	

### Dusting of the Pump Under Explosive Dust Environment:

1. Dust Layers should not form on the outer surfaces or inner parts of the pump
2. Dusting or Cleaning of the pump's outer surfaces must be done on regular basis or as per local Plant guidelines.
3. Dust should not accumulate or trap between moving parts insider the pump, as O-rings & seal rings are protecting against the entry. Clean the dust in case if you find traces inside the \*Dry Parts

\*Dry Parts: Dry parts are those parts which are not coming in process fluid contact.....such as Coupling Housing, Back Chamber, Pump Support Structure.

11.1 Diaphragm Replacement

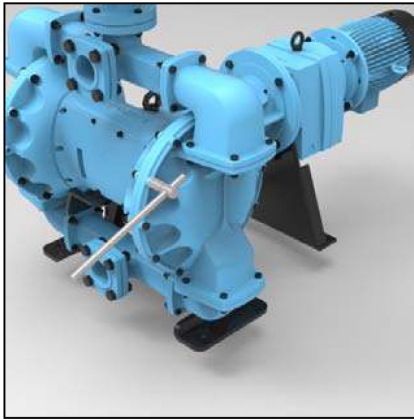

**Step 1** - Isolate the pump from pumping fluid and electrical connection, also have necessary tools and spares in hand.

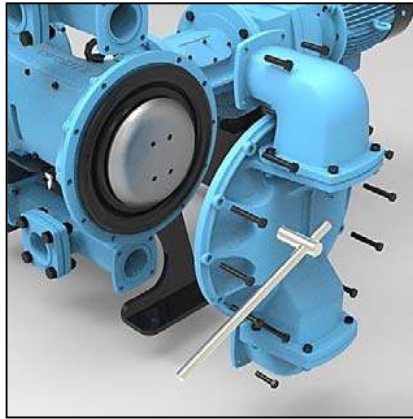

**Step 2** - Unfasten the bolts and pull the wet chamber, this might also be the right time to check O-Rings on suction and discharge flange.

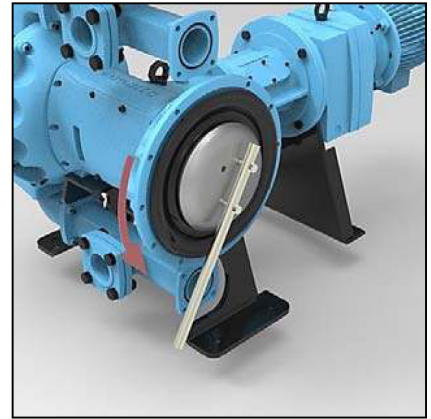

**Step 3** - Clean the holes and use the supplied tool "F-KEY" (aluminum only) and turn the diaphragm anticlockwise to unfasten it.

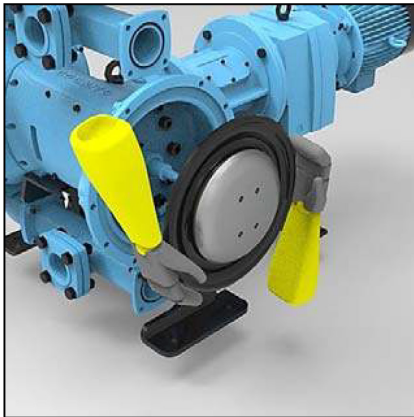

**Step 4** - Carefully pull the diaphragm assembly out, and keep the rear housing and shaft.

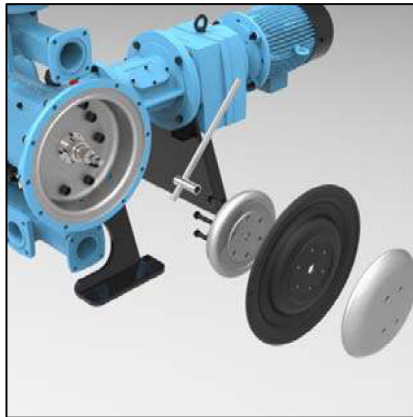

**Step 5** - The diaphragm is held between two bolted plates, these bolts are accessible from the rear plate. Clean the chamber completely.



**Step 6** - Replace the diaphragm and repeat steps in reverse order to assemble the pump, use star pattern to tighten the diaphragm assembly and wet chamber.

**Notes:**

1. If the diaphragm is not in the discharge position, take it in discharge position by rotating the motor fan manually.
2. Different Torque values are required for different Diaphragm type. Refer below table for Torque details.

**Torque Values for Different Diaphragm**

PUMP SIZE	NEOPRENE	SANTOPRENE	SANTOPRENE + PTFE
2"	-	30 Nm / 266 in-lb	30 Nm / 266 in-lb
3"	40 Nm / 354 in-lb	40 Nm / 354 in-lb	40 Nm / 354 in-lb
4"	40 Nm / 354 in-lb	50 Nm / 443 in-lb	50 Nm / 443 in-lb

## 11.2 Ball & Seat Cage Replacement

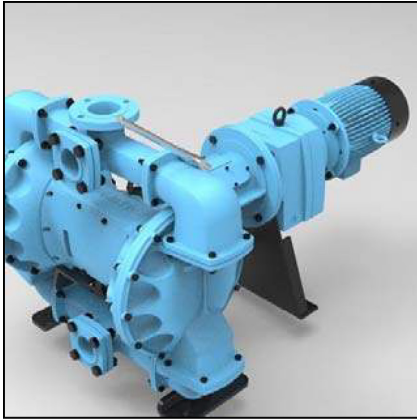

**Step 1** - Unfasten the upper bolts of the discharge elbow with necessary tools.

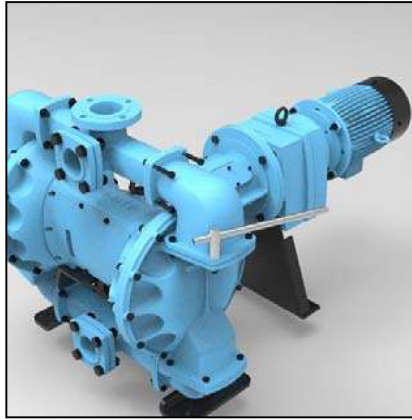

**Step 2** - Unfasten the lower bolts of the discharge elbow with the necessary tools.

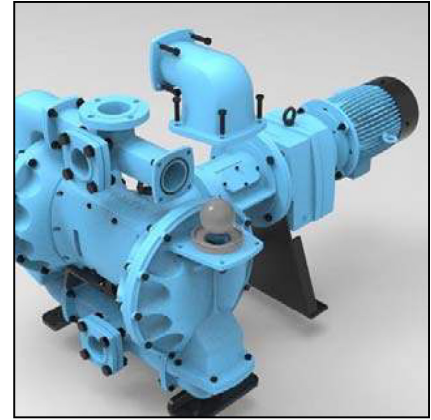

**Step 3** - Pull out the discharge elbow, check the valve and seat then replace it.

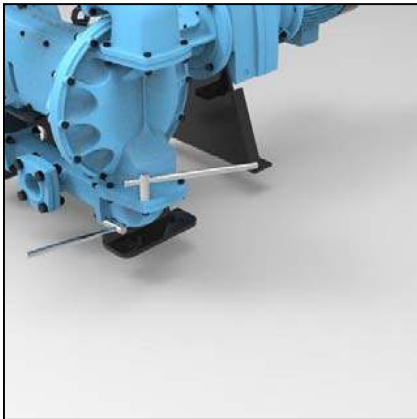

**Step 4** - Unfasten the upper and lower bolts of the suction elbow with the necessary tools.

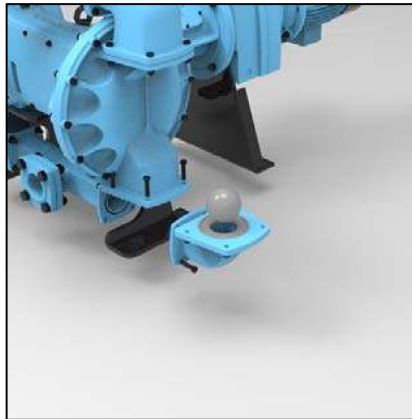

**Step 5** - Pull out the suction elbow, check the valve and seat then replace it.

## 11.3 Seal Replacement in Center Mechanism

1. To replace the seals, disassemble the wet-chamber, elbow, diaphragm assembly in sequence.
2. Now open seal housing , in which first slot is for Wiper seal & back slot is for rod seal.
3. After replacing it, place this seal sleeve in the back chamber of the pump.
4. Remove the worn out seals and replace with the new one using appropriate tool.
5. Please check the direction of the seals, V section opening should be on the oil side.

## 11.4 Seal Replacement for Dampener

1. Remove the dust cap and disassemble stopping pin by unscrewing the top bolt.
2. Take out seal housing by unscrewing 6 bolts.
3. Remove the damaged seals using appropriate tool.
4. Place new seals in the proper sequence.
5. There are two parts of seal – O-ring and SUPPORT RING. First Need to position O-ring in grooves and then add SUPPORT ring using appropriate tool.

### 11.5 Diaphragm Replacement for Dampener

1. Remove dampener from pump. Disassemble dampener by opening bolts of two halves.
2. Remove the dust cap and disassemble the stopping pin by unscrewing the top bolt.
3. Takeout diaphragm assembly. Unscrew the outer plate using grip and holding space provided on shaft.
4. Replace damaged diaphragms. Note that air side should face up.
5. Fix the outer plate with appropriate tool and using specified torque according to size.
6. Reassemble diaphragm rod assembly through the sleeve by applying grease to avoid frictional damage of seals & screw the stopper pin.
7. Assemble the two dampener's halves sandwiching the diaphragm using appropriate torque.

### 11.6 Disposal after Expiration of the Expected Lifetime

The metallic components like aluminum, stainless steel and carbon steel can be recycled. Plastic parts are not recyclable and must be disposed of as residual waste. The pump must be disposed of properly, according to local regulations. It should be noted that potentially dangerous fluid residues may remain in the pump and can create a hazard to the operator or the environment, therefore the pump must be thoroughly cleaned before disposal.

### 11.7 Residual Risks

Even with proper application and observance of all points listed in this operating manual, there is still an estimable and unexpected residual risk when using the pumps. It may leak, fail due to wear, application-related causes or system-related circumstances.

### 11.8 Actions in Emergency

In case of a leakage of an unknown fluid, respiratory protection should be worn and contact with the fluid should be avoided. During firefighting, no special hazards are to be expected from the pump itself. In addition, the currently handled fluid and the corresponding safety data sheet must be considered. When fluid leakage occurs, the power must be turned off, and the pressure released. During the spillage of an aggressive liquid, local and national safety rules must be followed.

### 11.9 Improving Pump's Longevity

1. Running the pump at the top-rated speed of the motor or more will cause premature wear to the pump's elastomers. We recommend running the pump at 20% less than the rated frequency (50 or 60 Hz) when using a VFD.
2. Post Shutdown, the particulate matter in pumping media may get deposited inside the pump chamber. Hence the pump should be emptied off any remaining media. Failure to do so, may rupture the diaphragm and other wearable part after consecutive start-up.
3. While operating the pump, do not exceed nominal working temperatures stated by the gearmotor manufacturer.
4. Maintain proper lubrication at all times.



## NOTICE

Follow the instruction, prior starting the equipment

- Check the oil level
- Clean the vent filter
- Open Inlet & outlet valves connected
- Follow the safety protocol's



## NOTICE

CLEAN THE MACHINE !

- Machine may JAM or contaminate the process upon subsequent use.





**12.1 Certification Standards & Markings**

ATEX Directive	2014/34/EU	EN ISO 80079-36:2016 EN ISO 80079-37:2016 EN ISO 60079-0:2018	
----------------	------------	---	---

**Hazardous location Markings:**

The non-electrical Ex h protection type used for the pump system is constructional safety type 'c'.

ATEX Marking	 II 2 G D	Ex h ia IIC T6-T3 Gb (Pump with sensor) Ex h IIC T6-T3 Gb (Pump without sensor) Ex h ia IIIC T85oC-T150oC Db (Pump with sensor) Ex h IIIC T85oC-T150oC Db (Pump without sensor)	DNV 23 ATEX 33382X
IECEX Marking		Ex h ia IIC T6-T3 Gb (Pump with sensor) Ex h IIC T6-T3 Gb (Pump without sensor) Ex h ia IIIC T85oC-T150oC Db (Pump with sensor) Ex h IIIC T85oC-T150oC Db (Pump without sensor)	IECEX DNV 23.0077X
UKCA Marking	 II 2 G D	Ex h ia IIC T6-T3 Gb (Pump with sensor) Ex h IIC T6-T3 Gb (Pump without sensor) Ex h ia IIIC T85oC-T150oC Db (Pump with sensor) Ex h IIIC T85oC-T150oC Db (Pump without sensor)	DNV 24 UKEX 33383X

**12.2 Specific Condition of Use**

1. Prevent electrostatic charges in potentially explosive areas – do not polish/rub nonconductive surfaces with a dry cloth. Warning – Potential Electrostatic charging hazard- see instructions.
2. Avoid direct impact or friction in the equipment parts containing light metals to eliminate thermite sparks.
3. All gaskets, O-rings and seals used for the EODD pumps shall have the continuous operating temperature at least 20K higher than the identified maximum service temperature of the pump.
4. When EODD pump considered as pump only it must be used with Ex Certified dampener to reduce the pulsation and vibration during the pump operation thus ensuring continuous and precise non pulsed flow rate.
5. When EODD pump considered as pump only it must be connected with the Ex certified leakage detection sensor for any leakage detection during intended use of the pump.
6. Instruction manual must be followed during installing, operating, and maintaining the pump unit.
7. Equipment temperature class depends upon the various ambient temperature specified in this certificate.

Cognito warrants that its products will be free from defects in material and workmanship for a period of 12 months following date of purchase from Cognito. Cognito products which fail within the warranty period due to defects in material or workmanship will be repaired or replaced at Cognito's option.

Parts subject to wear or misuse, such as Diaphragm, check balls, valve seats, stopper cage, oil seals and other parts showing signs of misuse are not covered by this limited warranty. Also, equipment, parts and accessories not manufactured by Cognito but furnished with Cognito products are not covered by this limited warranty and purchaser must look to the original manufacturer's warranty, if any. This limited warranty is void if the Cognito product has been altered or repaired without the consent of Cognito.

All implied warranties, including any implied warranty of merchantability or fitness for a particular purpose, are expressly negated to the extent permitted by law and shall in no event extend beyond the expressed warranty period. Cognito disclaims any liability for consequential damages due to breach of any written or implied warranty on Cognito products.

**Information reacquired while you contact factory.**

Before you contact the factory, note the model number and serial number of your pump. The serial number directs us to a file containing all information on material specification and test data applying to your specific pump. When ordering parts, Cognito Service Manual or Instruction Book should be consulted for the proper Part Numbers.

ALWAYS INCLUDE THE MODEL NUMBER AND SERIAL NUMBER WHEN ORDERING SPARE PARTS.